



SERVICE MANUAL Starbucks Interactive Cup™ Brewer



Manufactured by:

Cafection Enterprises Inc.

2355, Dalton, Quebec, (Quebec) G1P 3S3 Canada

Tel.: 1-800-561-6162 Fax: 1-800-463-2739

service@cafection.com www.avalonbrewer.com



Starbucks Coffee Company

Tel.: 1-888-494-5282

ocs@starbucks.com





Table of Contents

- 1 INTRODUCTION..... 5**
- 2 SAFETY INSTRUCTIONS..... 6**
- 3 WARRANTY..... 7**
 - 3.1 Warranty Policy..... 7**
 - 3.2 Warranty Return Procedure..... 8**
 - 3.3 Spare Parts Order Process..... 8**
- 4 REFERENCE DRAWINGS..... 9**
 - 4.1 External View..... 9**
 - 4.2 Rear View..... 10**
 - 4.3 Internal View..... 11**
 - 4.4 Selection Keypad..... 12**
 - 4.5 Brewer Assembly..... 13**
 - 4.6 Brewing Process..... 14**
 - 4.7 Hot Water Tank..... 15**
 - 4.7.1 Thermostat Board..... 15**
 - 4.8 Main Board..... 16**
 - 4.8.1 Main Board (PCB) Descriptions..... 17**
 - 4.8.2 Factory Settings..... 17**
- 5 CONTROLS & FEATURES..... 19**
 - 5.1 Features & Benefits..... 19**
 - 5.2 Specifications..... 20**
 - 5.3 Automatic Safety Features..... 21**
 - 5.4 Brewing Instructions..... 22**
- 6 INITIAL SETUP..... 23**
 - 6.1 Installation Site Requirements..... 23**
 - 6.1.1 Clearances..... 24**
 - 6.1.2 Chute Hole Dimensions..... 24**
 - 6.2 Unpacking..... 25**
 - 6.3 Preparing the Stand..... 26**
 - 6.3.1 Seismic Strap..... 26**
 - 6.4 Leveling the Equipment..... 26**
 - 6.5 Hot Water Tank Preparation..... 27**
 - 6.5.1 Tank lid preparation..... 27**
 - 6.5.2 Adjusting the water level switch..... 27**
 - 6.5.3 Adjusting the tank overflow float..... 28**
 - 6.6 Water Line Connection..... 28**
 - 6.7 Bean Hopper Installation..... 29**
 - 6.8 Electrical Connection..... 30**
 - 6.9 Water Temperature..... 31**
 - 6.10 Drip tray, side skirts and overflow..... 32**
 - 6.11 Loading Products..... 33**
 - 6.12 Chute System Installation..... 34**
 - 6.13 Filter Paper Installation..... 35**
 - 6.14 Installation Testing..... 36**
 - 6.15 Warranty Card..... 37**



Table of Contents Continued

7 SERVICE SOFTWARE..... 39

 7.1 Alarms..... 39

 7.2 Data..... 40

 7.3 Setup..... 40

 7.4 Data Tracking Sheet..... 41

8 CLEANING AND SANITIZING..... 43

 8.1 Cleaning and Sanitizing Instructions..... 43

 8.2 Recommended Cleaning Tools..... 43

 8.3 Cleaning and Sanitizing Schedule..... 44

 8.4 Overall Cleaning..... 45

 8.5 Exterior Cleaning..... 45

 8.5.1 Cleaning the Drip Tray..... 45

 8.5.2 Cleaning the Side Skirts..... 45

 8.5.3 Cleaning the Sensors..... 46

 8.5.4 Emptying the Waste Bin..... 46

 8.6 Interior Parts Cleaning and Sanitizing..... 47

 8.6.1 Automatic Rinse Cycle..... 47

 8.6.2 Cocoa Canister..... 48

 8.6.3 Coffee Brewer..... 49

 8.6.4 Coffee Hopper..... 50

 8.6.5 Fan..... 51

9 PREVENTIVE MAINTENANCE..... 53

 9.1 Schedule..... 53

 9.2 Brewer Assembly..... 54

 9.3 Water Outlet Valves..... 55

 9.4 Water Filtration System..... 55

 9.5 Hot Water Tank..... 56

 9.6 Grinder..... 57

10 SERVICING PARTS..... 59

 10.1 Draining the hot water tank..... 59

 10.2 Shutdown & Storage..... 60

 10.2.1 Storing the Brewer..... 60

 10.3 Brewer assembly..... 61

 10.4 Microcontroller (Eprom)..... 62

 10.5 Main Board..... 63

 10.6 Keypad membrane..... 64

 10.7 Logo Badge..... 65

 10.8 Ingredient Motor..... 66

11 TROUBLE SHOOTING..... 67

 11.1 LCD Messaging..... 67

 11.2 Parts Specific..... 68



SERVICE MANUAL Starbucks Interactive Cup™ Brewer

1 INTRODUCTION

The Interactive Cup™ Brewer is manufactured exclusively for Starbucks Coffee Company.

Cafecion manufactures the Interactive Cup™ Brewer based on its original single cup brewer technology and is complemented with the Starbucks look and feel and of course the Starbucks® coffee!

Cafecion's original single cup technology allows for fresh coffee beans to be ground on demand for each cup of coffee. It has also been recognized in the industry for its simplicity of use and maintenance as well as its reliability.

The Interactive Cup™ Brewer offers 2 choices of whole bean coffee that can be mixed upon request as well as gourmet hot cocoa and hot water.

The coffee is available in 4 sizes;
Short (8oz), Tall (12oz), Half Carafe (36oz) and Full Carafe (60oz)

The cocoa is available in 2 sizes;
Short (8oz.) and Tall (12oz)

In the following pages, you will find clearly illustrated and easy-to-follow instructions regarding:

- Safety Instructions
- Reference Drawings
- Controls and Features
- Initial Setup
- Service Software
- Cleaning and Sanitizing
- Preventive Maintenance
- Servicing Parts
- Troubleshooting

BEFORE YOU START

These brewers have been manufactured to comply with the highest sanitation, safety and performance standards. To maintain this degree of safety and performance, it is important that the installation and maintenance be performed in accordance with the recommendations made in this service manual. Any changes to the construction or wiring can be hazardous to the user. The brewer must not be altered in any way and only *genuine replacement parts* must be used for the preventive maintenance and repair including filter paper.

This document refers to the specifications, parameters and user interface of the Interactive Cup™ Brewer brewers V1B and may differ from the previous Interactive Cup™ Brewer V1 units.



The steps outlined in “Initial Set-Up” of this manual must be completed before plugging in the Brewer!!!



2 SAFETY INSTRUCTIONS

Basic safety precautions should always be followed when using electrical appliances. Read all instructions before using this brewing equipment.

Food-Contact Parts

- We recommend that you clean and sanitize all food-contact parts prior to installation and use. See the cleaning and sanitizing section for more details

Warnings

- To minimize the risk of fire or electric shock, do not expose this equipment to rain or moisture.
- Do not immerse this equipment in water; it could lead to electric shock and or other malfunctions.
- Do not use this equipment other than for its intended use.
- This equipment contains hot water; extreme caution must be used when moving it.
- This brewing equipment is intended for indoor installation only.

Power supply

- Always use a grounded 120V AC 60Hz socket outlet rated for 15Amps service.
- Each piece of brewing equipment must have its own electrical outlet, on a dedicated circuit.
- Extension cords may not be used.
- This equipment is equipped with a polarized alternating current line plug (one blade wider than the other). Only use this plug with an outlet in which the prongs can be fully inserted. Avoid any exposure of the prongs on the polarized plug.

Disconnect the equipment if:

- Damage is done to the power cord;
- The equipment doesn't work properly;
- The temperature of the power cord or plug increases dramatically during use;
- Unusual conditions occur.



FAILURE TO COMPLY CAN CAUSE EQUIPMENT DAMAGE, FIRE OR SEVERE BODILY INJURY.



3 WARRANTY

3.1 Warranty Policy

We hereby certify that the products manufactured by Cafection are, to the best of our knowledge, free from all defects and faulty workmanship. The following warranties and conditions are applicable:

All parts in contact with water (outlet valves, heating element, thermostat, probe, inlet valve and tank float) are warranted against material and workmanship defects for 90 days from date of shipment by Starbucks to the customer plus 10 days.

All remaining parts of the brewer are warranted against material and workmanship defects for one year from date of shipment by Starbucks to the customer plus 10 days.

All warranty service and returns must have prior authorization from Cafection. Please contact Cafection customer service at 1-800-561-6162.

Conditions

Cafection assumes no responsibility for substitute replacement parts installed on the Interactive Cup™ brewer that have not been purchased from Cafection.

The following circumstances will void the warranty policy:

- Improper installation or operation of the equipment.
- Abuse or neglect, including but not limited to, failure to follow the preventive maintenance schedule.
- Variation in equipment performance due to excessive mineral deposit or local water conditions.
- Equipment altered in any way and/or dates, codes or serial numbers removed or modified.
- Equipment damaged in shipping from the customer to Cafection due to improper packaging.

Please note that labor is not covered by the warranty and that the repair protocol is limited to replacing the defective part. Should any additional repairs need to be done, they will be charged to the customer.

Equipment or parts will not be accepted without a copy of the original invoice indicating delivery date and serial number.

Please return your warranty card to Cafection via mail or fax to validate your warranty and register your unit for part upgrades.



Cafection Enterprises Inc.
2355, Dalton
Ste-Foy, (Quebec) G1P 3S3
Canada

Tel.: 1-800-561-6162
Fax: 1-800-463-2739
E-mail - order@cafection
www.cafection.com



3.2 Warranty Return Procedure

In order to always offer you better, faster service, we request your cooperation for the return of parts under warranty. We thank you in advance for taking the time to follow this procedure:

1. Please contact the Customer Service department to obtain an authorization for return.
2. You will be asked to fax a **Parts Return Form** supplied in Appendix A and copy of the original invoice with date of receipt and serial number of the unit in question to Cafecton at (1-800-463-2739) for approval.
3. Do not destroy any parts before receiving a written confirmation that this part will or will not be credited or exchanged.
4. A copy of the original invoice and **Parts Return Form must be included** with your parts returned.



PLEASE MAKE SURE THE MERCHANDISE IS WELL PACKED!
Please use original packaging!

5. Once the merchandise is received, Cafecton will check the parts and apply a credit to your account or exchange the merchandise if the warranty is applicable. Only guaranteed parts are authorized for return.
6. We suggest you keep replacement parts on hand.
7. The warranty covers only **regular shipping**. Overnight shipping charges will be applied to your order. Orders must be received before 12:00 pm Eastern Standard Time to leave the same day*.



** Some conditions may apply. Replacement parts will be charged to the account until the original guaranteed parts are returned. In the event a customer does not have an account open with Cafecton, the parts will have to be prepaid via credit card.*

FOR MORE INFORMATION, PLEASE CALL CUSTOMER SERVICE AT 1-800-561-6162

3.3 Spare Parts Order Process

In order to always offer you better, faster service, we request your cooperation for the order of spare parts. We thank you in advance for taking the time to follow this process:

1. Please complete the **Parts Order Form** supplied in Appendix B.
2. Fax a copy to Cafecton at 1.800.463.2739 attention Customer Service.

**TO EXPEDITE YOUR ORDER, PLEASE MAKE SURE YOU INCLUDE
A PURCHASE ORDER NUMBER!**

3. We suggest you keep replacement parts on hand.
4. Overnight shipping requests will be charged to your order. Orders must be received before 12:00 pm Eastern Standard Time to leave the same day*.



**PRIOR TO ORDERING PARTS, YOU MUST HAVE A CURRENT ACCOUNT OPENED WITH
CAFECTON OR PRE-PAY YOUR ORDER VIA CREDIT CARD.**



SERVICE MANUAL Starbucks Interactive Cup™ Brewer

4 REFERENCE DRAWINGS

4.1 External View

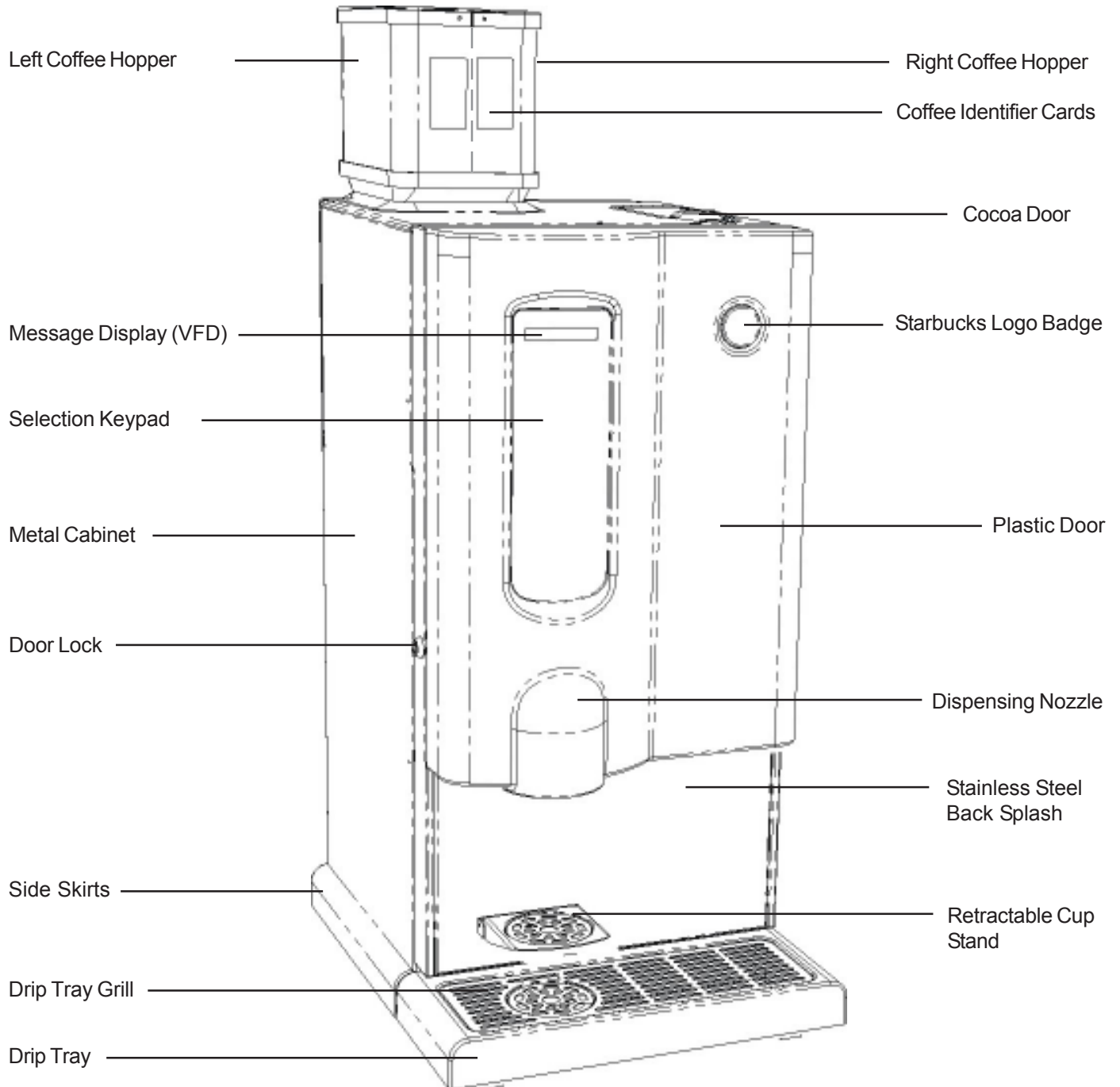



4.2 Rear View

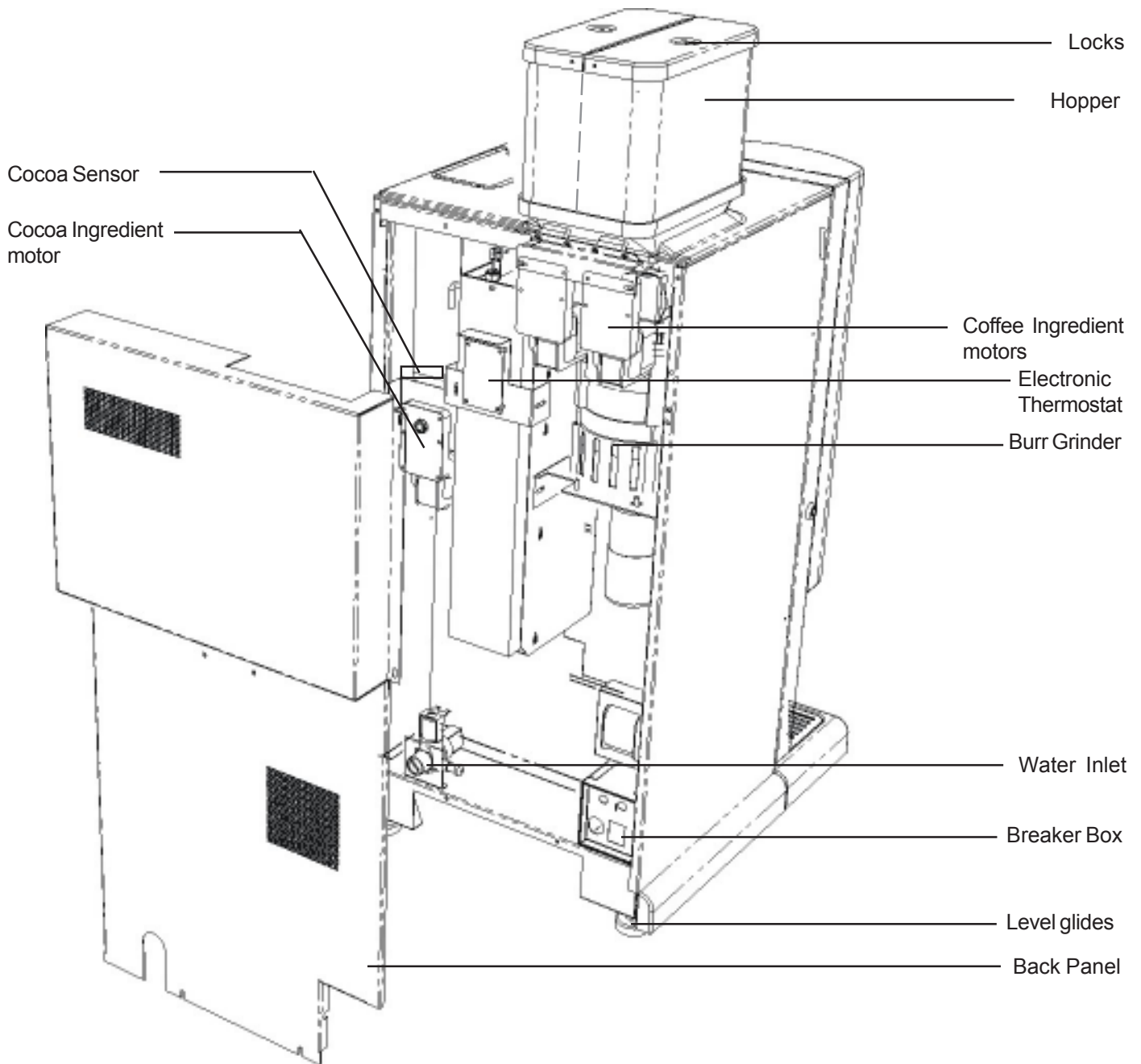



4.3 Internal View

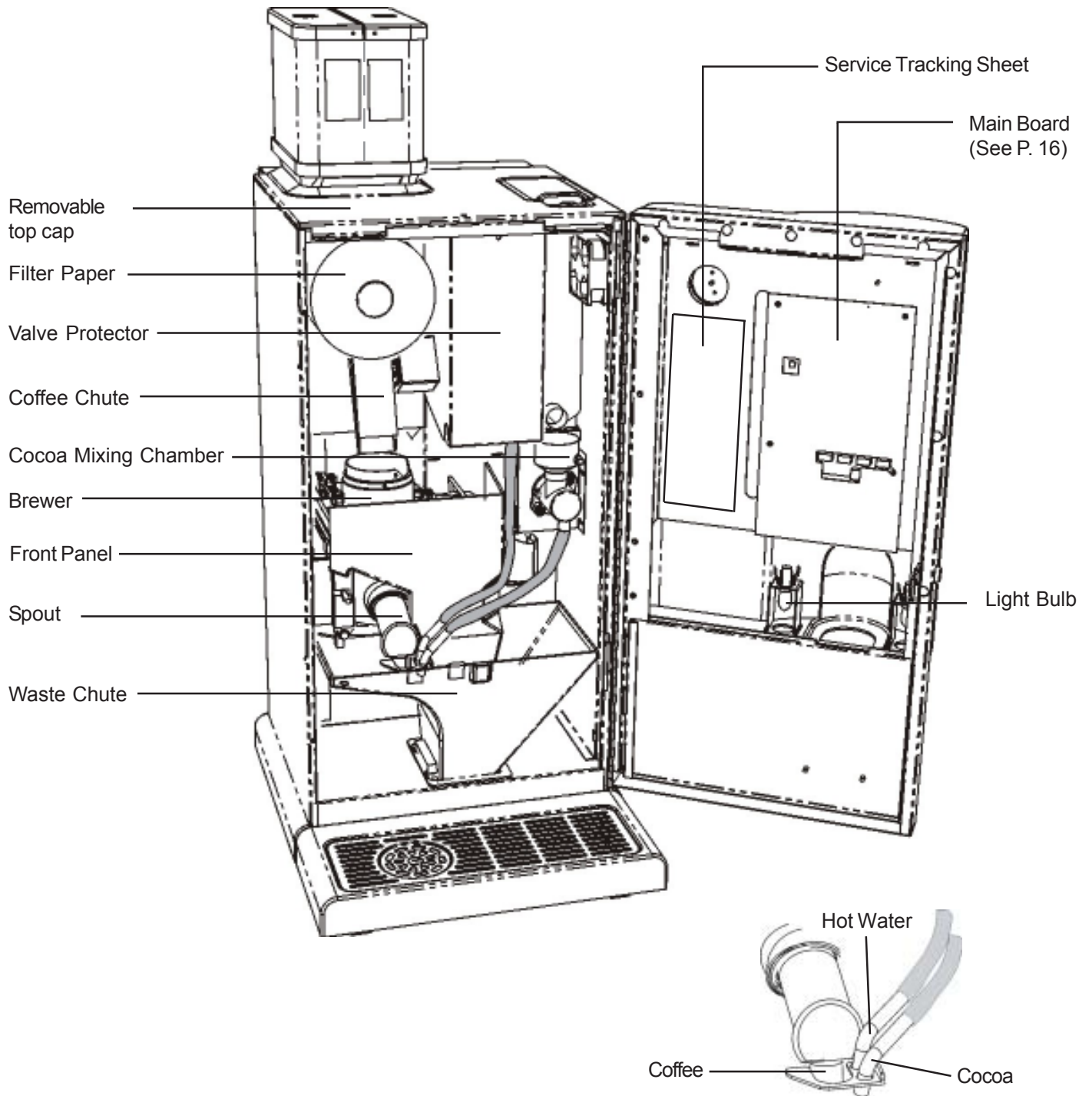



4.4 Selection Keypad



The user interface is clearly divided into three steps:

1. Choose a size
2. Choose a beverage
3. Brew

Each step is illuminated in white to guide you through the beverage ordering process, and each button is illuminated to indicate your selection. The display will indicate the steps and communicate messages.

If a selection is not illuminated, it is not a valid selection (i.e.. carafe of cocoa).



SERVICE MANUAL Starbucks Interactive Cup™ Brewer

4.5 Brewer Assembly

The Starbucks Interactive cup™ brewing system is in a class of it's own in the single cup coffee industry. Its vacuum extraction process, joined with a high quality filter paper, brews a coffee of unsurpassed quality to meet the taste profile of the best coffee connoisseurs. Best of all, this is available for every cup of coffee at any time of day. See the following page for the description of the brewing process.

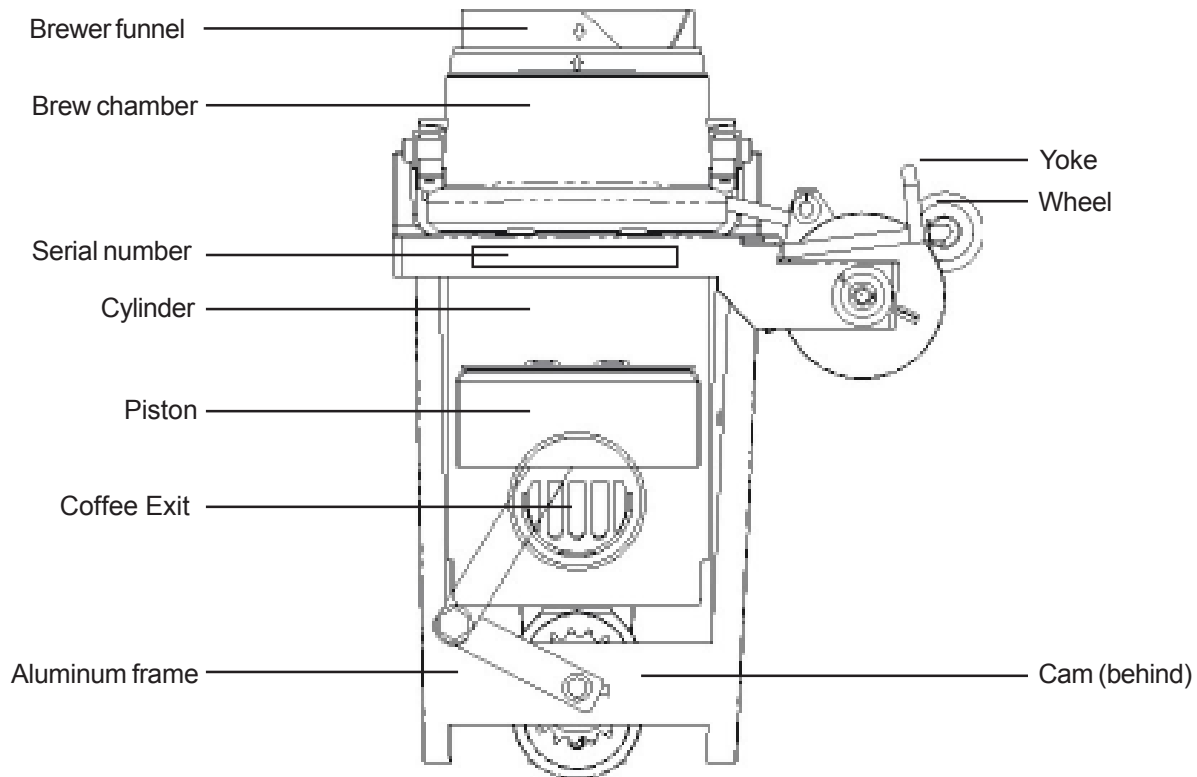



4.6 Brewing Process

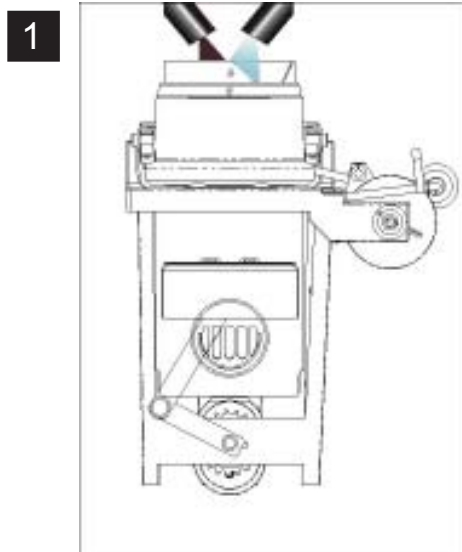

Step 1 Ascent of the piston

The ground coffee and the water are dispensed into the brew chamber during the ascension of the piston. This compresses the air in the cylinder and forces it through the coffee mixture in the brew chamber thereby agitating the brewing coffee.

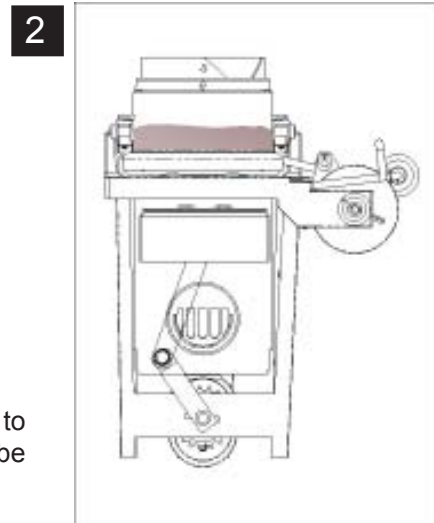

Step 2 Pauses

Once the piston has reached its top dead point, it will pause to allow the coffee to brew to the appropriate strength. There will be one shot of water before the descent to rinse the chamber.

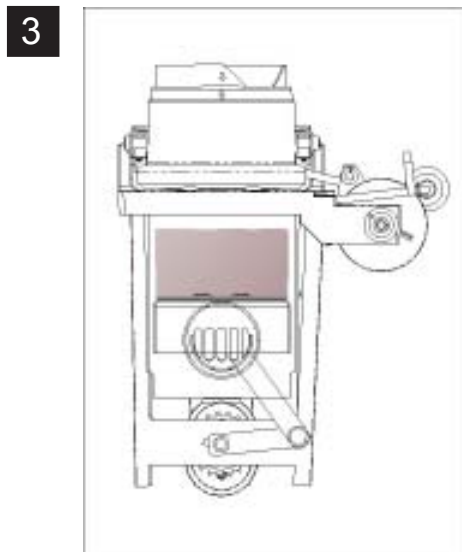

Step 3 Descent of the piston

The descent of the piston will create a vacuum thereby extracting the coffee from the grounds through the filter paper and into the cylinder. One last pause will be to allow all the coffee to drip from the brew chamber.

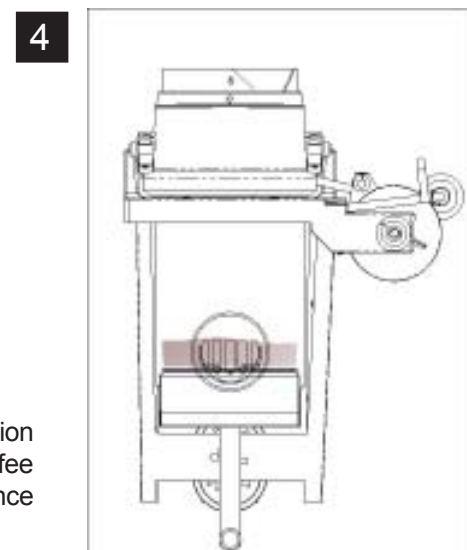

Step 4 Product delivery

The piston follows its course heading to its low dead point. Distribution of coffee through the spout begins once the piston is below the coffee exit. Meanwhile, the brew chamber lifts to allow the paper to advance thereby discarding the spent grounds into the waste chute.



4.7 Hot Water Tank

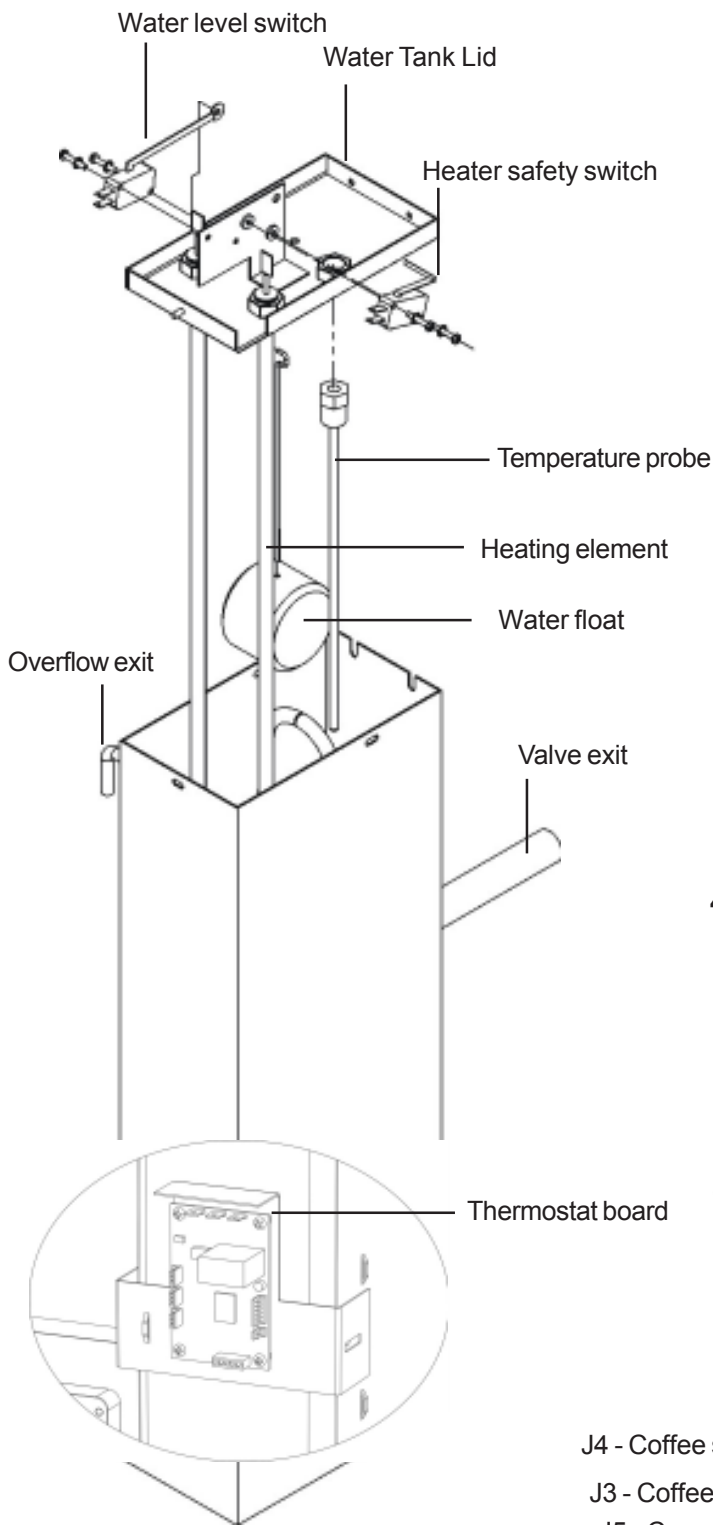

4.7.1 Thermostat Board

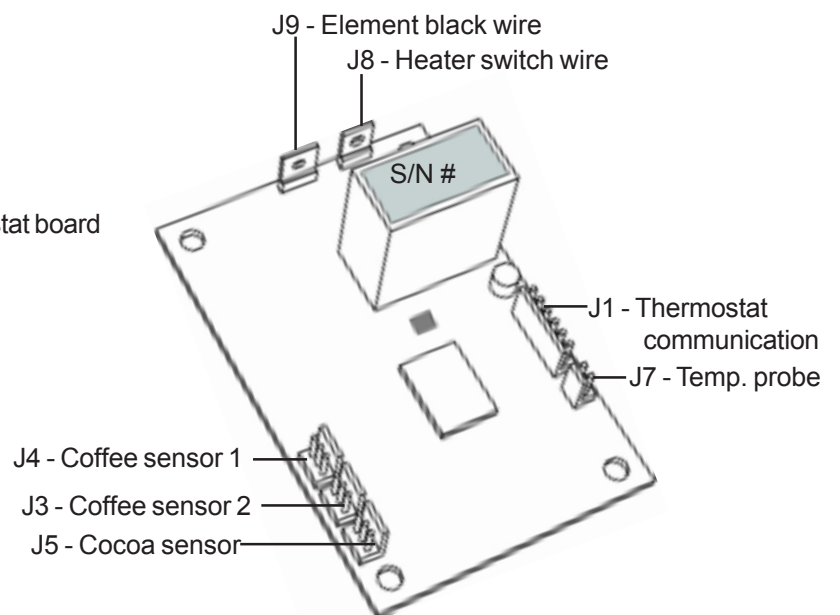



4.8 Main Board (PCB)

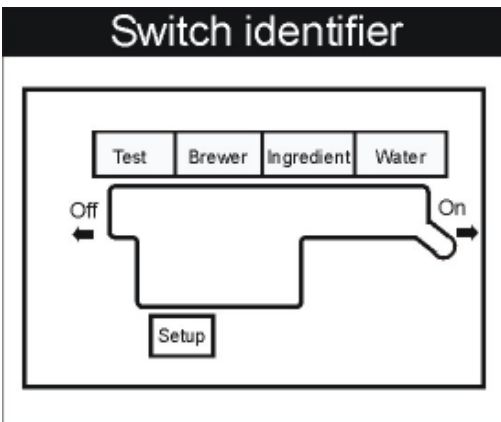
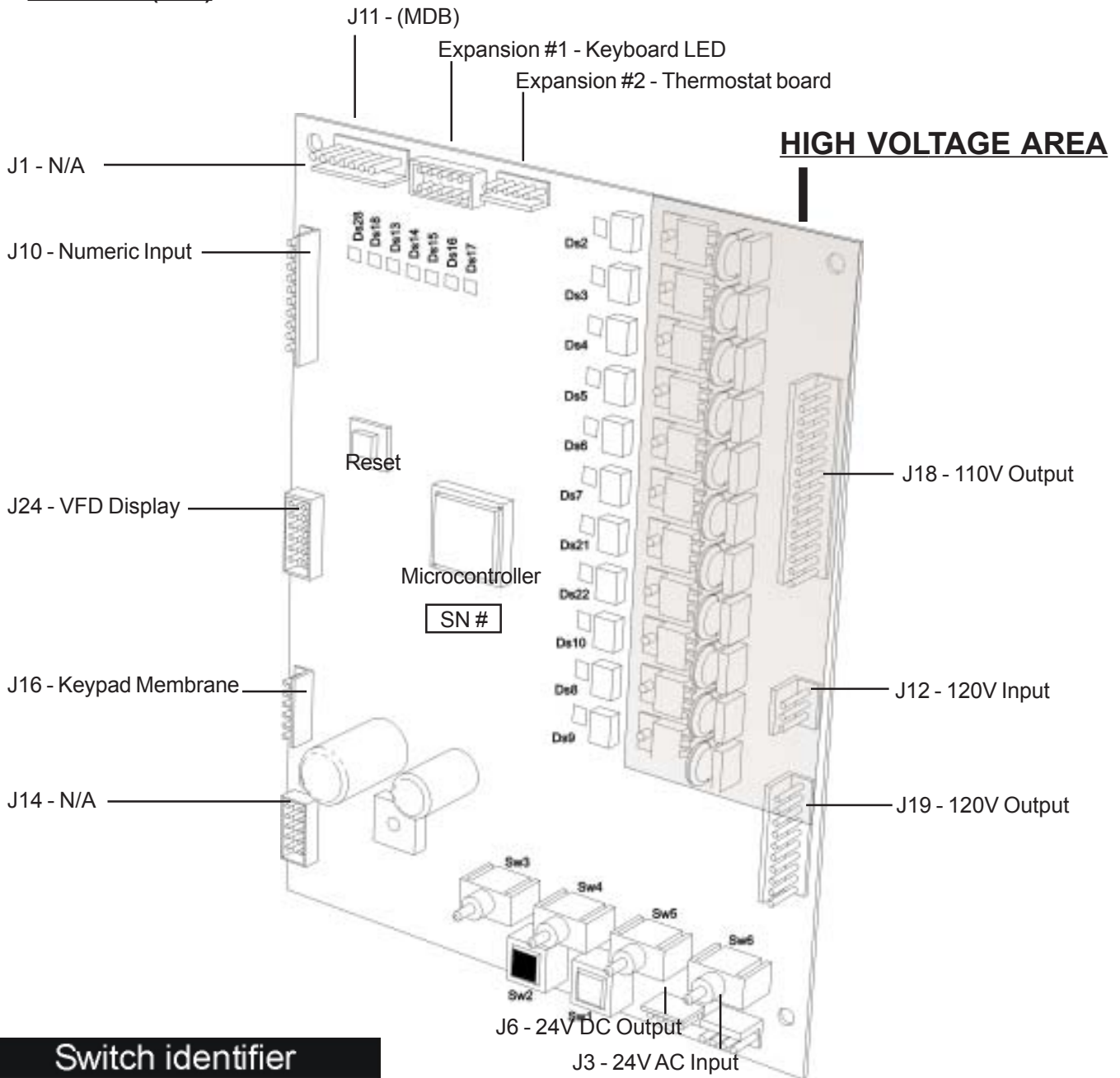

This is a schematic reference drawing only. Not to scale.



The equipment should always be unplugged from the electrical outlet before servicing any components within this main board assembly.



4.8.1 Main Board (PCB) Descriptions

Interactive switches and buttons

- 1. Reset button (Red)**
Pressing this button initializes the Interactive Cup™ (same as the on/off switch)
- 2. Temperature button (SW1) White**
Pressing this button and holding it down will indicate the actual water temperature in the tank.
- 3. Setup button (SW2) Black**
Allows access to the user data and machine software parameters.
- 4. Test Switch (SW3)**
ON, this switch allows you to bypass the warming up mode to access the brewer functions when installing. For default user mode, the switch should be off.
- 5. Brewer Switch (SW4)**
ON, the switch lifts the brewer head to allow the filter paper replacement. or default user mode, the switch should be off.
- 6. Ingredient Switch (SW5)**
Allows the neutralization of the ingredient dispensing motors (Regular and Decaf coffee and cocoa). At OFF, the motors will not dispense ingredients.
- 7. Water Switch (SW6)**
Allow the neutralization of the water dispensing valves (Coffee, hot water, cocoa). At OFF, the valves will not dispense water.

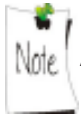

All units ship with the switches in the off position.

Green LEDs

The green leds will illuminate to indicate the alarm that has been triggered.

- DS28** - Waste bin full
- DS18** - Drip tray overflow
- DS13** - Brewer cam error
- DS14** - Filter paper required
- DS15** - Low water level
- DS16** - N/A
- DS17** - N/A
- DS19** - Warming up
- DS20** - N/A
- DS25** - N/A
- DS27** - N/A
- DS26** - N/A
- DS24** - N/A
- DS23** - N/A

Red LEDs

The red leds will illuminate to indicate the part is in use.

- DS2** - Grinder motor
- DS3** - Right coffee motor
- DS4** - Coffee water valve
- DS5** - Cocoa motor
- DS6** - Cocoa whipper & water valve
- DS7** - Brewing light
- DS21** - Hot water valve
- DS22** - Brewer motor
- DS10** - Inlet valve
- DS8** - Left coffee motor
- DS9** - Solenoid
- DS12** - N/A
- DS11** - N/A

4.8.2 Factory Settings

In the event you need to rest the software back to the factory settings:

- 1) Press the **Red** Reset button
- 2) Press and hold both the **Black** and the **White** button
- 3) The Display will ask you to confirm you wish to reset the factory settings
- 4) Press the **Hot Water** button to do so
- 5) Press the **Cocoa** button to exit.



This page is intentionally left blank.



SERVICE MANUAL Starbucks Interactive Cup™ Brewer

5. CONTROLS & FEATURES

(Also see the User Brewing and Care Manual)

5.1 Features & Benefits

The equipment is fully automatic, so there's no measuring, no separate grinding and no mess - just a consistently delicious cup of coffee or cocoa, every time you brew.

FEATURE	BENEFIT
Preset settings and features	Always the same consistent taste with no calibrations, no measuring, and no mess.
Cocoa level sensor	Will automatically remind you when the cocoa canister needs to be filled.
Limited access	All product access is limited by locks including hoppers and the stand.
On demand rinsing	To ensure the highest level of sanitation, the brewer will automatically notify the user when it's time to rinse.
Bean to cup	Whole Bean flavor and freshness, ground to perfection - every cup, every time.
Gourmet cocoa	Enjoy a gourmet hot cocoa whipped to perfection every time.
Multi-cup capability	Eliminate waste, brewing only what you need - from one cup to a half or full carafe.
Default selections	Preset a 1-touch default beverage via the service software.
Coffee house experience, without leaving your office	Experience a variety of delicious Starbucks® coffees and delicious gourmet cocoa as in the coffee house.
State of the art brewing technology	The brewing system is in a class of it's own in the single cup business offering an unsurpassed coffee beverage quality to meet the taste profile of the best coffee connoisseurs.
User-Friendly, electronic touch-button control panel	Brewing steps and selection buttons are illuminated to guide the user through the ordering process.
Service Software	Allows the Operator to control features of the machines, diagnostic messages and keep track of all data.



5.2 Specifications

Beverage Selections

- 2 Whole Bean coffees (Regular and Decaf)
- Right and Left coffee blend
- Gourmet hot cocoa
- Hot water
- 2 cup sizes Short 8oz & Tall 12oz available for all beverage selections
- 2 carafe sizes Half 36oz & Full 60oz available for all coffee selections

Product Capacities

Left whole bean hopper: 2 lbs
 Right whole bean hopper: 2 lbs
 Cocoa canister: 4 lbs

Machine Dimensions

Base Stand Dimensions

Total Dimensions

Height: ...42".....	26.5".....	68.5"
Width:16".....	18.5" (x2).....	37"
Depth:22.5".....	25.5".....	25.5"
Weight: ...125 lbs.....	65 lbs (x2).....	255 lbs

Filter Paper

Capacity: 1600 cups

Water Tank

Capacity: 1.5 gallon
 Water valves: 3 valves
 Heating element: 1250 watts

Electrical requirements

110 volts
 15 amp circuit
 60 Hz

INTENDED FOR INDOOR USE ONLY



5.3 Automatic Safety Features

There are various safety mechanisms on this brewing equipment to prevent a machine malfunction resulting in material damages.

Water Level Switch and Heater safety switch

The water level switch and the heater safety switch work together to ensure that the heating element is deactivated if there is insufficient water in the tank. The water level switch is controlled by a float and will shut off the inlet valve when the tank is full. If the level in the tank gets too low, the heater safety switch will be triggered and the heating element will be turned off. For more information, see section 6.5.2.

Overflow switch

If the water were to boil, the tank water would go into the overflow cup and all machine functions would be turned off. This is a fatal error. This could also be triggered if the float in the tank was defective or if the machine was moved while the tank was full. The unit would appear Off. For more information, see section 6.5.3.

Overflow drip tray

This will be triggered if the drip tray is full or if something is leaking inside the unit. This will deactivate the water inlet valve thereby preventing the element to heat. The display would indicate "Drip tray full". For more information, see section 6.10.

Software safety features

At the time of the first tank fill, the water inlet valve will close after 4.5 minutes of continuous demand. This is the amount of time necessary to completely fill the tank. After the initial tank fill, the inlet valve will close after 20 seconds of continuous demand. This safety mechanism is designed to prevent water from flowing continuously into the machine due to a mechanical malfunction. The display will indicate "Low water level"

If the low water level switch is triggered but not the heater safety switch, the element will automatically be shutoff. This is in the event of a mechanical failure of the heater safety switch.

Heating element safety feature

In the event of an element and thermostat failure, the thermostat board sensor would detect this and shut off the element at 250 degrees thereby preventing a fire hazard. This would also prevent the element from heating with no water in the tank. "Low water level" will be indicated on the display.



5.4 Brewing Instructions

* Choose a size *

This screen is always on when the equipment is in the default user mode.

Step 1: Place your cup:



Paper Cup or Mug

Make sure you verify whether your Starbucks cup has an 8oz or 12oz capacity and center it on the cup stand.

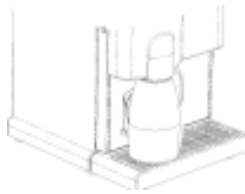

Carafes

If you are using a large travelling mug or a carafe, raise the cup stand to comfortably fit under the dispensing nozzle.

Step 1: Choose a size:

Same as user card



Carafe

Half carafe is 3 12oz cycles
 Full carafe is 5 12oz cycles
 A confirmation is required when ordering a carafe.
 Cocoa option is not available in Carafe sizes.

Step 2: Choose a beverage:



Hot Water

To order Hot water, press and hold the hot water button to dispense up to 8oz of Hot water. Press and hold the button again for more hot water.

Step 3: Brew:



Push Start to begin the brew cycle or Cancel to return to step 1. When Cancel is pressed during the carafe brewing process, the current cycle will be completed.

While brewing, the cup area will illuminate and the display will indicate a cycle progress bar. No other features are available during the brewing process.



6 INITIAL SETUP

Before you install the brewer on location, we strongly suggest that it be unpacked and inspected before you leave your warehouse. This unit is quite heavy and we recommend 2 people for transporting the unit or the proper equipment to do this safely.

Overview of Installation Steps

- 6.2 Unpacking
- 6.3 Preparing the Stand
- 6.4 Leveling the Equipment
- 6.5 Hot Water Tank Preparation
- 6.6 Water Line Connection
- 6.7 Bean Hopper Installation
- 6.8 Electrical Connection
- 6.9 Water Temperature
- 6.10 Drip tray and side skirts installation
- 6.11 Loading Products
- 6.12 Chute System Installation
- 6.13 Filter Paper Installation
- 6.14 Installation Testing
- 6.15 Warranty Card



Only Starbucks® Certified Service Technicians are authorized to install and service this equipment.

6.1 Installation site requirements

Operating environment

For indoor use only

Power Supply

Ensure that this unit will have its own electrical circuit and located within 6 feet of the dedicated electrical outlet. Use only a polarized grounded receptacle.

Domestic 115 VAC / 60 Hz - 15 Amp Circuit

Water Supply

Should be a plastic 1/4" O.D. dedicated line branched off a larger line. An easily accessible shut off valve up stream of the unit is highly recommended for ease of installation.

Water pressure should be at least 20 PSI and no more than 80 PSI

Tools Required

#2 Philips screw driver
Regular medium Pliers
Adjustable wrench
Level indicator



Other tools may be required depending on the type of water supply tubing and location.



6.1.1 Clearances

Unit	Clearances	Allowance for:
Height: 42"	7"	Filling the coffee hopper.
Width: 16"	6"	Per side. Key access on one side and door swing on the other.
Depth: 22.5"	10 3/4"	Front when the door is open.
	6"	Clearance of water hookup, hoses, water filtration system and adequate air circulation.

(Measurements do not include the stand)

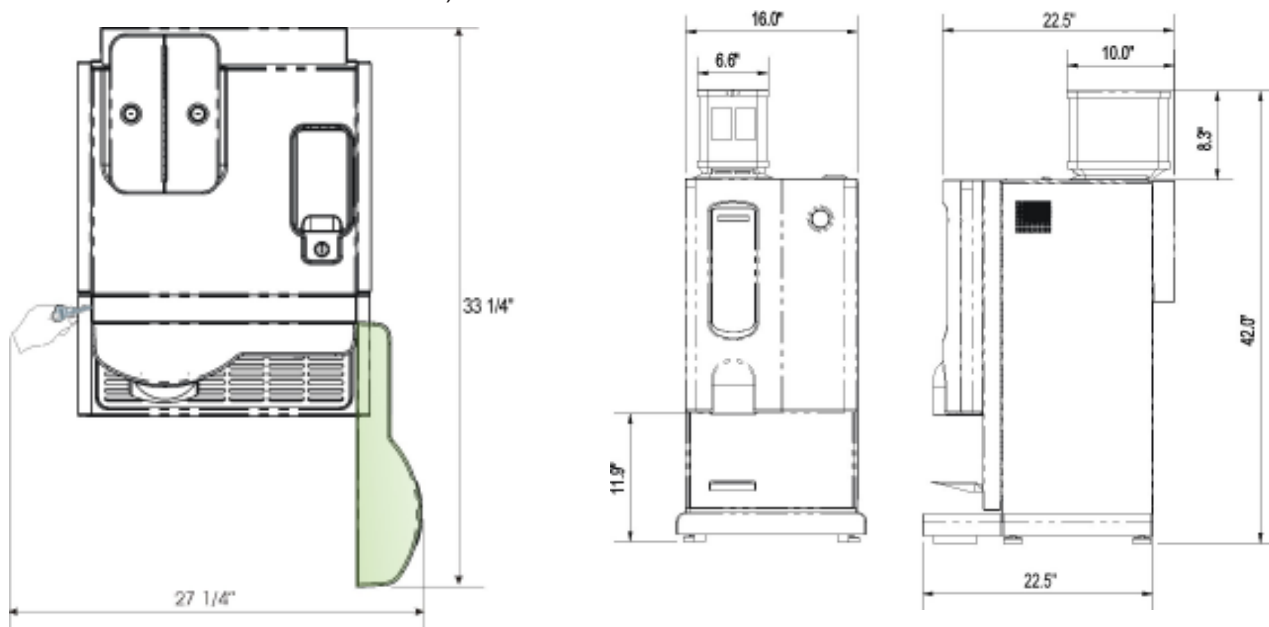

6.1.2 Chute Hole in Existing Countertop

In the event the location does not allow the use of the Starbucks base cabinet and you are required to cut a hole in the existing counter top, please refer to the below guidelines.

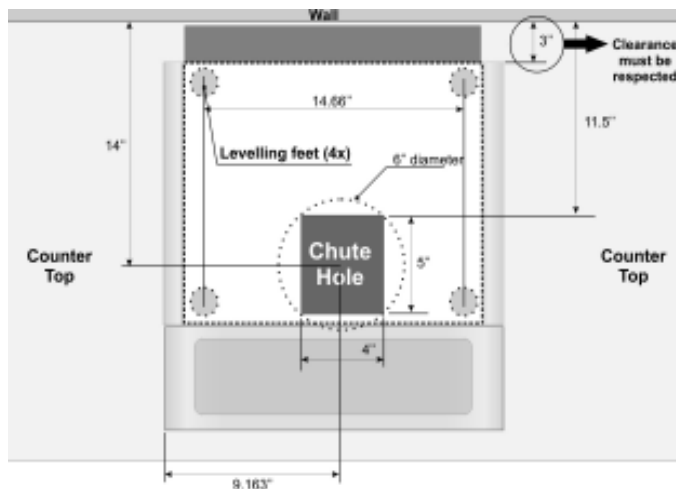



SERVICE MANUAL Starbucks Interactive Cup™ Brewer

6.2 Unpacking

Each brewer comes in a single box. Inside the box, you will find an accessory box.

To remove the unit from the box, carefully cut the straps holding the packaging together. Carefully cut open the top flaps to access the accessory box. Remove it and then lift the box up. Inspect the unit to see if any damage has occurred in shipment.

The parts and accessories that are shipped separately need to be installed on your equipment. In each box, you should find the following items:

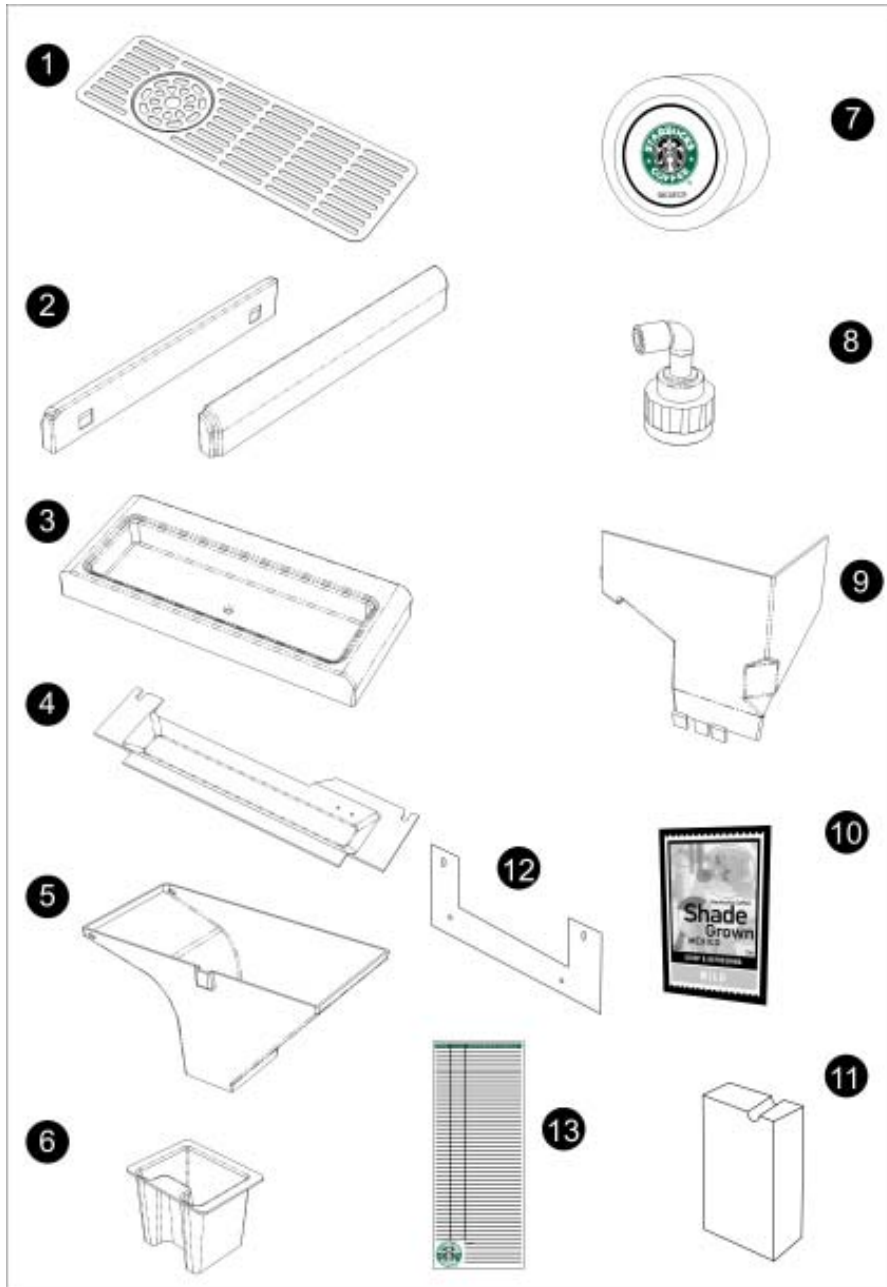

1. Drip Tray Grill
2. Side Skirts (Right/Left)
3. Plastic Drip tray
4. Overflow Drip Tray
5. Chute
6. Chute Base
7. Filter paper
8. 1/4" Inlet Kit Fitting
9. Front Panel
10. Coffee Identifier Cards (2)
11. Water level jig
12. Stand bracket
13. Service tracking sheet
14. Plastic bag containing the Service Manual

* The keys for the unit and the cocoa door are attached to the power cord located on the back of the unit.



6.3 Preparing the Stand

Install the stand by using the manufacturer instructions located inside the stand box.

With the help of another person, lift the brewer by the bottom of the metal cabinet onto the stand and carefully center it on the stand and the waste bin hole. **Do not lift by the plastic door.**

Install the metal stand bracket by screwing it first to the base of the equipment in the U shaped position, center the machine on the stand and then screw it to the stand. The screws are pre-installed on the machine in their dedicated location.

Install a large waste basket of 7-14 gallon capacity with bags in the cabinet below the equipment. The ideal waste basket is as tall as possible to the top of the cabinet. This will help to contain the used filter paper and avoid grounds getting into the cabinet. Use plastic garbage bags to facilitate the emptying and reduce the cleaning for this part.

6.3.1 Seismic Strap

Starbucks recommends that for machines installed within seismic regions, all local installation codes are strictly adhered to. These codes may include the attachment of a seismic strap between the Starbucks Interactive Cup™ brewer and a structural wall to limit the mobility of the machine in the event of an earthquake.

Starbucks recommends the following strap for installation to meet these requirements:

Company: Worksafe Technologies Northwest, Inc.
 Item Number: TSMST2118B
 Description: 2-18" Tekstraps, buckles, triangle plates w/screws, 1" x 3" swivel adhesive plates.
 Order Info: Straps can be ordered from the website www.eqhomesafety.com or by calling 1-206-284-6226.
 Price: The price for the strap is about \$25.

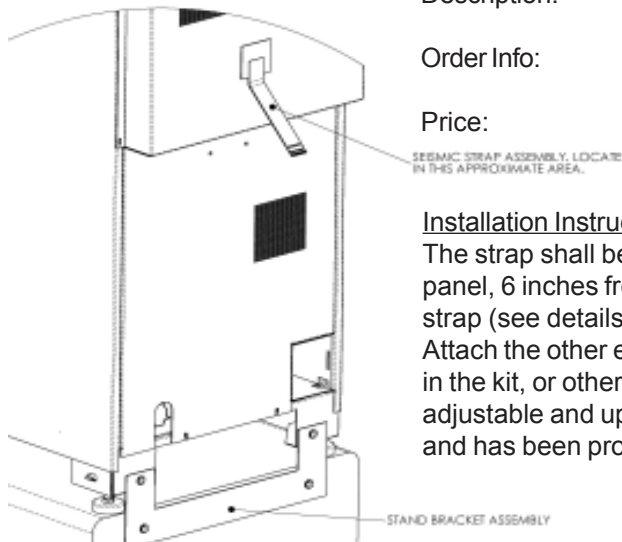

Installation Instructions:

The strap shall be attached to the machine at the center of the machine's back panel, 6 inches from the top of the machine using the self adhesive pad on the strap (see details at the side).

Attach the other end of the strap to the nearest wall using the fasteners provided in the kit, or other similar fastener of equal or greater strength. The strap length is adjustable and upon completion of the machine setup, ensure the strap is taut and has been properly adjusted to minimize slack.

6.4 Levelling the Equipment

For optimal performance of the equipment, it is important to ensure that it is leveled. Avoiding to do so can create variations in product delivery.

1. Place a level on the top of the machine;
2. Unscrew the leveling glides approximately 3/8". Verify this by installing the overflow tray. The tray should fit easily around the exposed threads;
3. Adjust the 4 threaded level glides or legs of the equipment to reach a leveled position.



6.5 Hot water tank preparation



Make sure equipment is unplugged!

6.5.1 Tank Lid preparation

1. Open the door of the equipment;
2. Remove the plastic top cap of the machine by lifting and pulling towards you;
3. Unscrew the tank cover in order to access the tank lid.
4. Locate the water tank and remove the twist-tie securing the float of the water tank;
5. Remove the silicone tubing on the heating element;
6. Connect the double white wire to the prong on the heating element;
7. **Adjust the water level switch;**
8. Replace the top lid and close door.

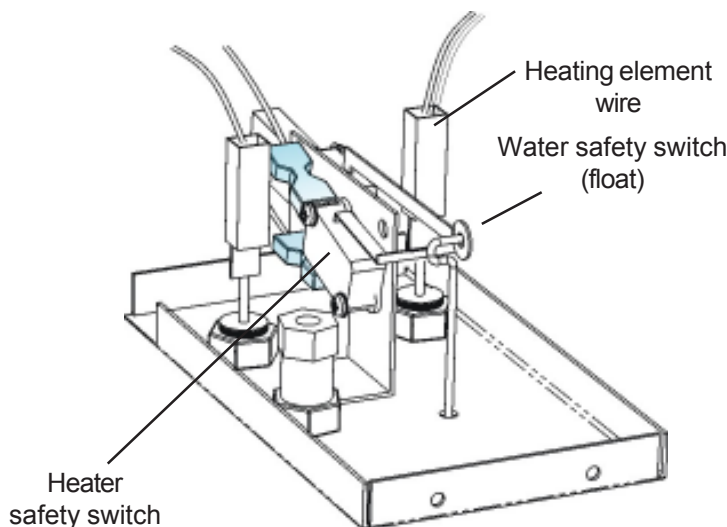

Left side view

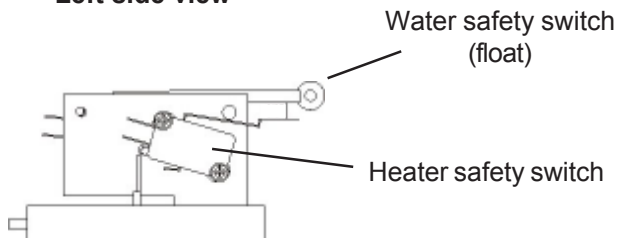

Right side view

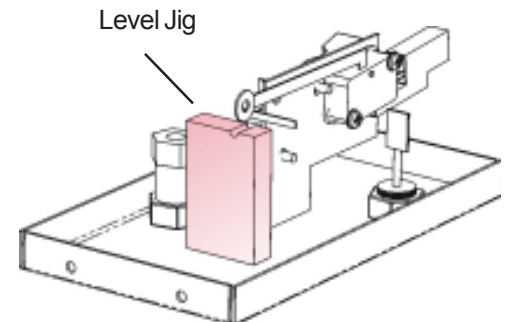
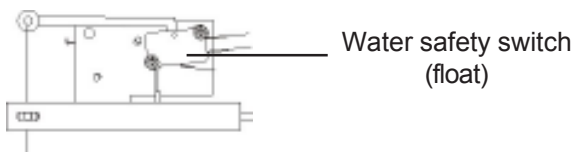

6.5.2 Adjusting the Water Level Switch

The water in the hot water tank relies strictly on gravity. Therefore, it is important to adjust the water level switch at the time of installation to ensure the appropriate water pressure in the tank for accurate water delivery. A water level jig is supplied in the accessory box to help you find the appropriate level.

1. Place the jig under the end of the water level switch with the groove side up;
2. The switch should click to its on position when it reaches the bottom of the groove;
3. If you need to adjust it, very delicately bend the arm of the switch to the desired position;
4. Also verify that the water level switch triggers the heater safety switch only once it has reached its dead low position. The only time they should touch is in a cutoff situation.

CAUTION - Over-bending the arm may break it and will prevent it from functioning



6.5.3 Adjusting the Tank Overflow Float

It is important to verify that the float is positioned appropriately in the overflow cup since it can move around in transportation. If this float is not in place the switch will not be activated and the unit will automatically shut down sensing an overflow situation.

It is important to verify that the Overflow cup is in place with the highest side in the front and secured with the red tape. If you need to remove this cup, please make sure that you replace it with the highest section facing the front and the overflow tube in the cup. Fasten in place with tape. This will ensure that the float will “float” and will activate the overflow switch if there is a problem.

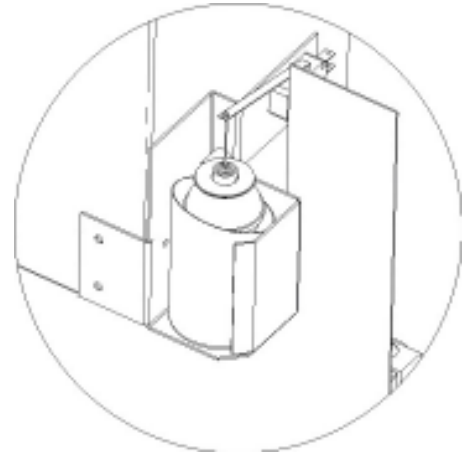

6.6 Water Line Connection



This equipment must be installed in compliance with applicable Federal, State and/or Municipal plumbing codes having jurisdiction.

Make sure that the equipment is unplugged before proceeding with the water supply installation. Also verify that the incoming water pressure is greater than 20 psi and no more than 80 psi.

1. Prior to installing the unit, flush out the water line by running approximately 1 gal. of water into a pail. This will ensure no sediment from a new installation can get in the unit;
2. The incoming water supply should have a shut-off valve connected in-line. Water supply should be a plastic ¼” O.D. dedicated line branched off a larger supply line;
3. Make sure your water source is turned off. Secure the inlet fitting firmly onto the inlet valve. Do not overtighten;
4. Make sure the equipment is unplugged. Connect the water line to the quick connect inlet fitting;
5. Turn the water valve on, sending water to the brewer. If there are any leaks, tighten connections to stop leakage.



This procedure does not take into consideration the installation of a water filtration system. Please refer to the water filter manufacturer installation instructions and incorporate them into the above.

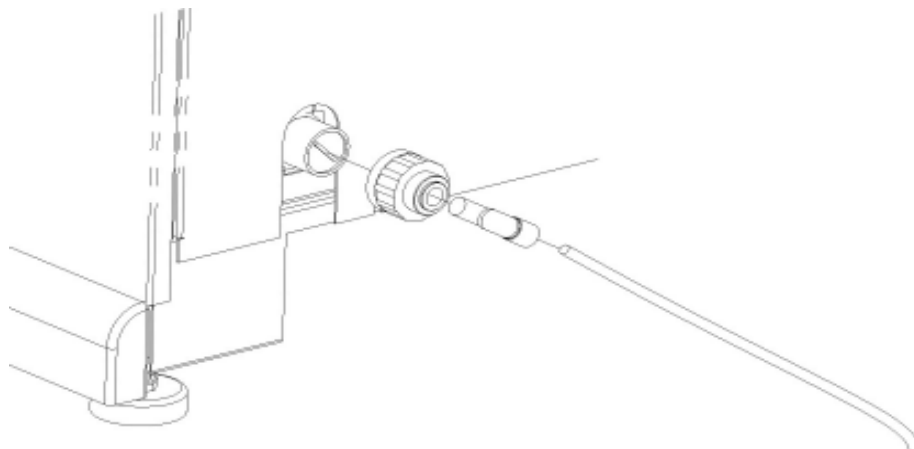



6.7 Bean Hopper Installation

Fig. 1.1

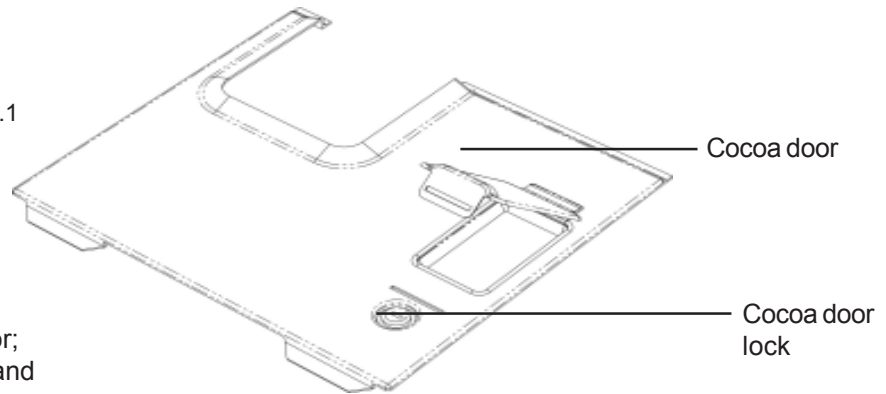

Step 1 Removing the top cap

1. Unlock and open the main door;
3. Remove the top cap by lifting and pulling toward you;
4. Verify that the coffee grinder is not obstructed.

Step 2 Installing the Coffee Hopper

1. Align the canister transmission in the motor transmission (fig 1.2);
2. Align the metal lock with the hole in the front of the canister to the base;
3. Push the canister to the back;
4. Rotate the lock to latch in the groove of the metal pin (fig 1.4).

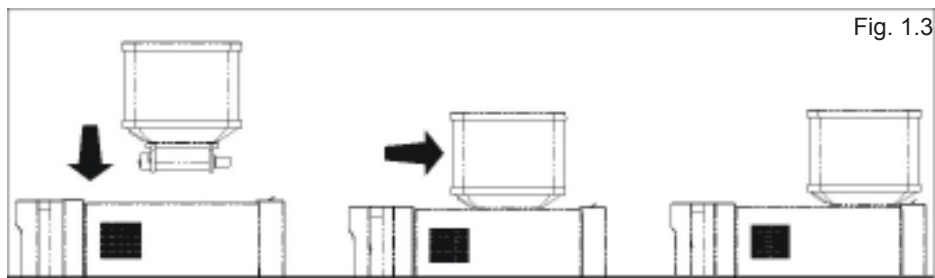
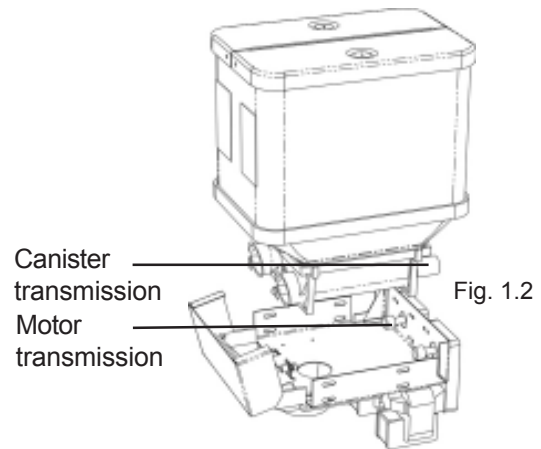

Step 3 Reinstalling

1. Reinstall the top cap;
2. Install the coffee identifier cards of the blend you are using in the card holders located on the front of the hopper.

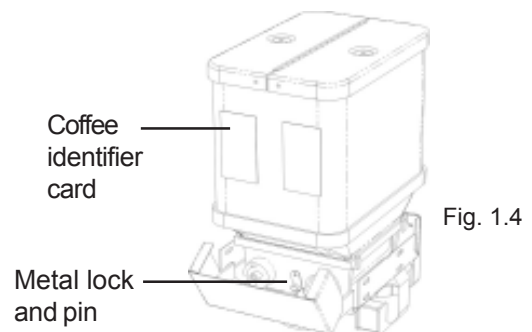



6.8 Electrical Connection



This equipment must be installed in compliance with applicable Federal, State and/or Local electrical codes having jurisdiction.

- Make sure:**
- The equipment is OFF before plugging it in,
 - The equipment has its own electrical outlet and
 - An extension cord is not used.

1. Make sure that the power switch in the back of the unit is in the OFF position before plugging in the unit;
2. Locate the unit's 6 foot power cord and plug it into its own grounded electrical outlet;
3. Reach to the back of the brewer and toggle the power switch to the On position. The front lights will go on, and water will automatically enter the brewer. The tank will fill in 2-3 minutes from the moment the brewer is turned on;
4. Once the tank is full, it will take 15-20 minutes to heat the water to brewing temperature. During this time the LCD will indicate "Warming up...";
5. The brewer is not available during the warm-up. At installation, you may bypass this by toggling the SW3 switch on the power board. This will give you access to the unit to complete your tests. Don't forget to switch it back or the warm-up procedure will not work;
6. Once the brewing equipment is ready, the LCD will indicate "Choose a size".

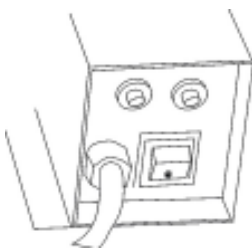

The main power switch turns the equipment off and on. This switch should be turned OFF when servicing any (AC line voltage) electrical components on the equipment.



6.9 Water Temperature

This equipment has a coffee brewing setpoint of 195 F water temperature to offer a consistent beverage quality for the users. There is a +/- 2 degree F tolerance. If the temperature falls below 15 degrees of the setpoint, the machine will indicate “Warming up” and will not be available until the temperature has been recovered. To read the actual temperature status of the equipment, simply:

1. Open the door;
2. Toggle the test switch (SW3) to on;
3. Press and hold the white button (SW1) on the main board.

The display will indicate:

Water temperature 000 F ---> 195 F

The left is temperature reading, right indicates setpoint.

4. Important! Return the test switch (SW3) to off!

This is an average and is not what you would get from a manual temperature measure. The actual water temperature fluctuates since cold water enters the tank after every beverage delivery and time is required to heat the incoming water up to the setpoint.

You can also take the water's brewing temperature manually by ordering a cup of hot water and measuring its temperature with a thermometer. There may be a slight difference from the tank reading. This is normal.

If you are experiencing large temperature differences, verify that your tank is clean and not obstructed by mineral deposits and scale.

Unit safety measures

In the event of a temperature probe failure, the tank may start to boil. This will cause it to overflow into the “Overflow Cup” and will automatically shut off the unit. Otherwise, the thermostat board also has a heat detector and will shut off the machine if the tank's temperature exceeds the acceptable range.

Electronic thermostat of the hot water tank

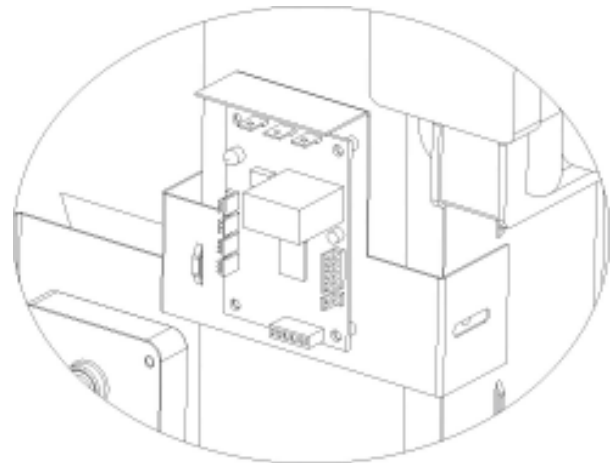



6.10 Drip tray, side skirts and overflow tray installation

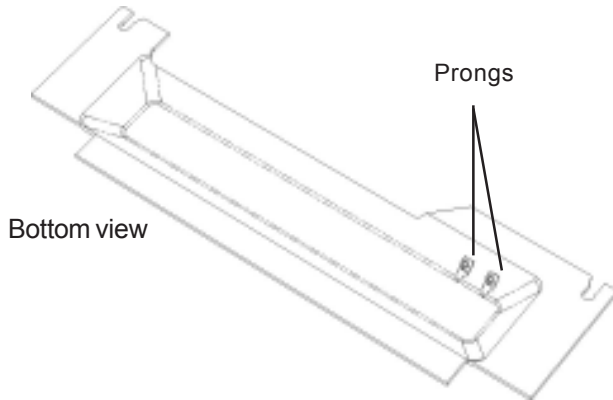

1. Connect the overflow sensor wires found inside the machine and fastened with a tie wrap, to the prongs underneath the overflow tray;
2. Unscrew the level glides approximately 3/8" and slide the overflow tray underneath the brewer and secure onto the level glides;
3. Install the two side skirts to the sides of the unit;
4. To install the drip tray, insert the two drip tray pins in the holes at the bottom of the brewer, under the door and insert the two side skirts;
5. Finally, put the drip tray grill in the drip tray and validate with the carafe that it fits comfortably under the dispensing nozzle.

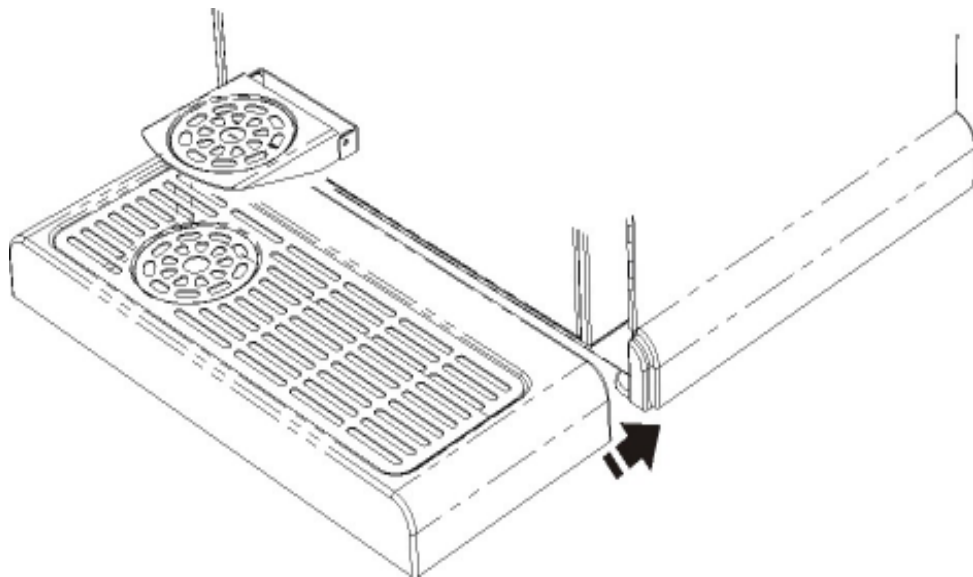



6.11 Loading Products

Unlock and open only the lid of the appropriate section and fill the whole bean coffee hopper compartments with Starbucks® coffee until it reaches 1 inch from the top. Wipe away any beans that may have spilled on the top cap of the equipment.

To fill the cocoa canister, verify if there are beans in the cocoa door lock area, remove if any. Unlock and open the door on the top right of the machine top cap and fill until it reaches the top of the black funnel or 2 inches from the lid.

Make sure that the lids close comfortably. Do not overfill. Lock the hopper lids and wipe any spills on the top cap of the equipment.

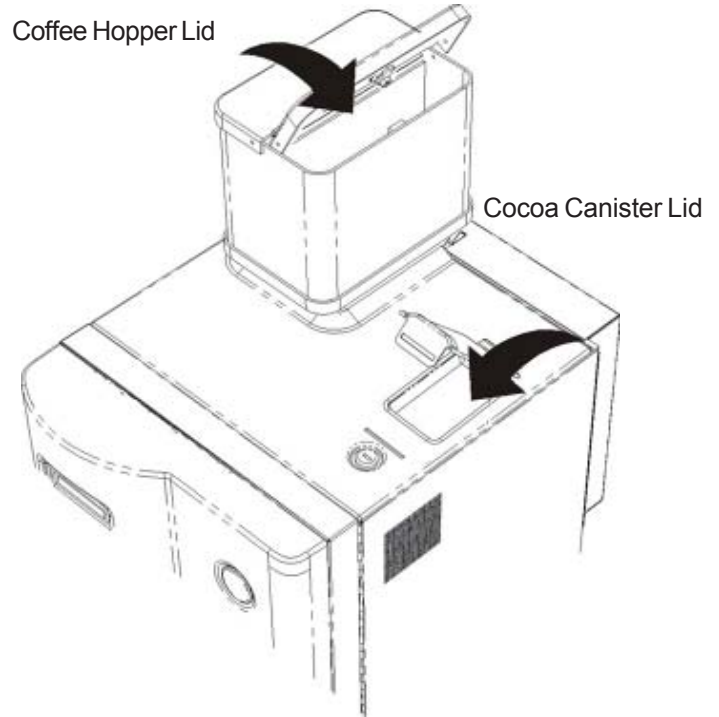

To prevent coffee beans from falling into the cocoa canister, and eventually obstructing the cocoa dispensing tube, always make sure that there are no beans in the cocoa lock area.



6.12 Chute system installation

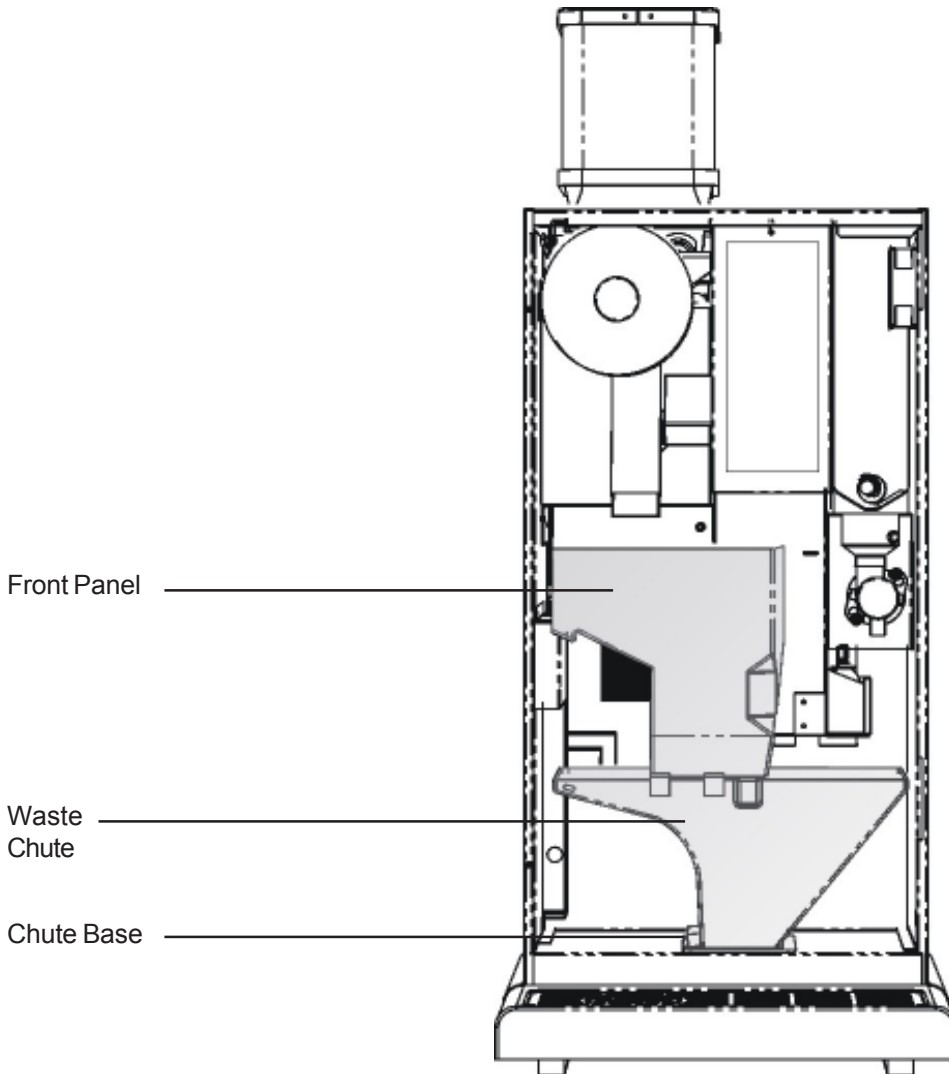

1. Open the door of the equipment;
2. Insert the chute base through the chute hole of the cabinet with the indent on the left;
4. Insert the large waste chute into the chute base;
5. Install the front panel onto the chute by aligning the prongs to the left of the catch and clip onto the left side of the brewer assembly.



6.13 Filter paper installation



Only use Starbucks® Interactive Cup filter paper (4 1/16" wide) which is good for 1,600 cups of coffee.

1. Make sure the power to the brewer is ON;
2. Place the roll on the paper support bracket so that it dispenses on the left hand side; (See the diagram inside the brewer)
3. Toggle the brewer paper switch to ON (SW4 on the main board, see page 16), the brew chamber will rise;
Note: the brew chamber will not rise if the switch does not sense filter paper
4. Pass it under the left guide bracket of the brew group, under the brew chamber and under the wheel guides by gently lifting them by the yoke;
5. Pull on the paper and route it through the cabinet chute hole and into the waste bin;
6. Make sure that it is feeding straight. Verify that it stays within the first guide. Improperly placed filter paper will cause a vacuum leak and may cause grounds to spill off into the machine.
7. Toggle the brewer paper switch back to the OFF position (SW4 on the main board);
8. The filter paper will advance while the brewer assembly cycles and the brew chamber comes down on the paper, ready for the next cup.

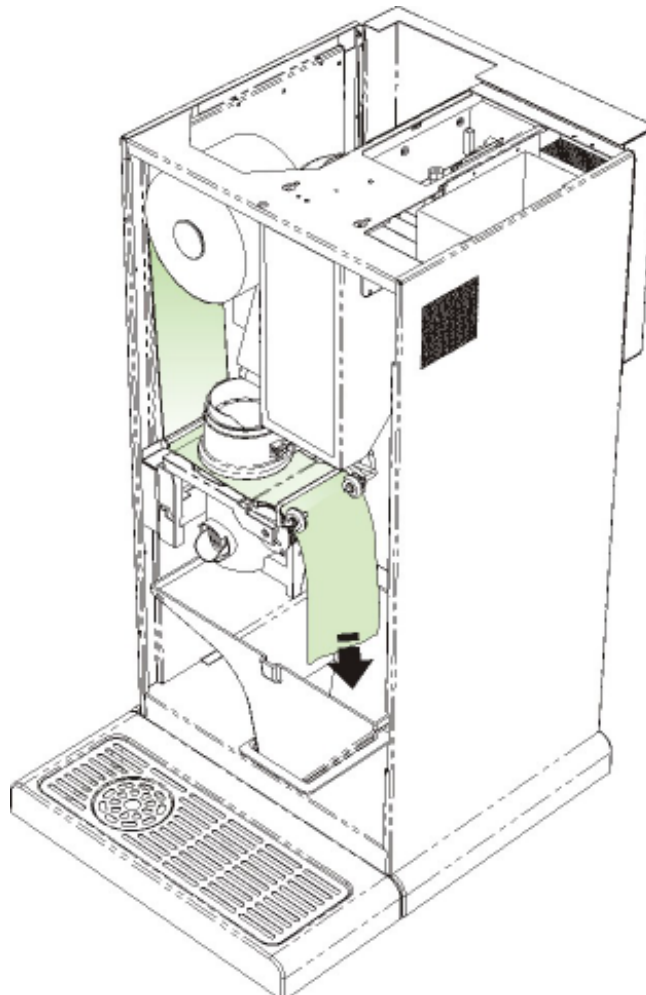



6.14 Installation testing

It is important to have the unit perform several cycles before completing the installation. It is important that you order one full carafe of left coffee, one full carafe of right coffee and one tall Cocoa to insure that the machine is operating as per the specifications laid out in this manual. During this process, review the check list as a reminder.

You need to be sure that each machine is clean, safe and functioning when you leave it.

	What to check	Remedy, if it is not	Pg.#
<input checked="" type="checkbox"/>	Inlet valve is free from leaks	Verify that it is secure and not overtighten	28
<input checked="" type="checkbox"/>	Brew chamber is empty of coffee	Verify that the unit is leveled	26
<input checked="" type="checkbox"/>	The coffee grounds stay inside the chute system when dispensed	Verify that the chute is properly installed	34
<input checked="" type="checkbox"/>	Cocoa mixing bowl is free of leaks	Verify that it is on straight and tube is secure	--
<input checked="" type="checkbox"/>	Filter paper feeds without resistance and goes straight into the waste bin	Repeat the installation procedure	35
<input checked="" type="checkbox"/>	Cup stand is sturdy and folds back completely to the back splash with ease		--
<input checked="" type="checkbox"/>	Carafe fits easily under the dispensing nozzle with cup stand folded back	Adjust the level of the equipment	26
<input checked="" type="checkbox"/>	Water temperature is acceptable	See water temperature	31
<input checked="" type="checkbox"/>	Equipment is secured to the stand	Install the metal U-shaped bracket to secure	26
<input checked="" type="checkbox"/>	Water filtration system is installed	This is strongly recommended	--
<input checked="" type="checkbox"/>	Products are loaded	Refer to this manual	33
<input checked="" type="checkbox"/>	Coffee identifier cards are in place	Verify that they are not in the accessory box	29
<input checked="" type="checkbox"/>	Brewer and area are clean and tidy	Please tidy up	--
<input checked="" type="checkbox"/>	Test switch is at OFF	Toggle to off	30



6.15 Warranty card

Install the service tracking sheet in the inside panel of the door to the left of the main board. See the cleaning and maintenance section for suggestions on how to use the sheet.

Fill out the warranty card and fax or send it in the mail to Cafectio to validate your warranty and register your unit for part upgrades.



This page is intentionally left blank.



7 SERVICE SOFTWARE

(Use Service Overlay included)

The software allows you to control the machine parameters and retrieve data from the equipment.

To access the Software:

1. Unlock and open the door of the equipment
2. Press the black SET UP button located on the lower section of the main board (SW2 see page 16)
The display will indicate:

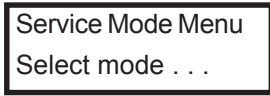

Service Mode Menu

- Alarms: Status
- Data: User and alarm data
- Setup: Machine parameters

Controls

- Arrows: Toggle from one message to another
- Enter: Confirms your selection
- + / -: Increases or decreases the values
- Clear: Clear the last data entered
- Reset: Exits the mode + service mode

7.1 Alarms

The Alarms status allows the operator to see at a glance all of the alarms that are presently triggered on the equipment. If there are alarms, the display will toggle to display each message. Attend to the issue indicated in the display, to resolve the alarm error and press clear in this section.

If there are no alarms, the display will indicate:

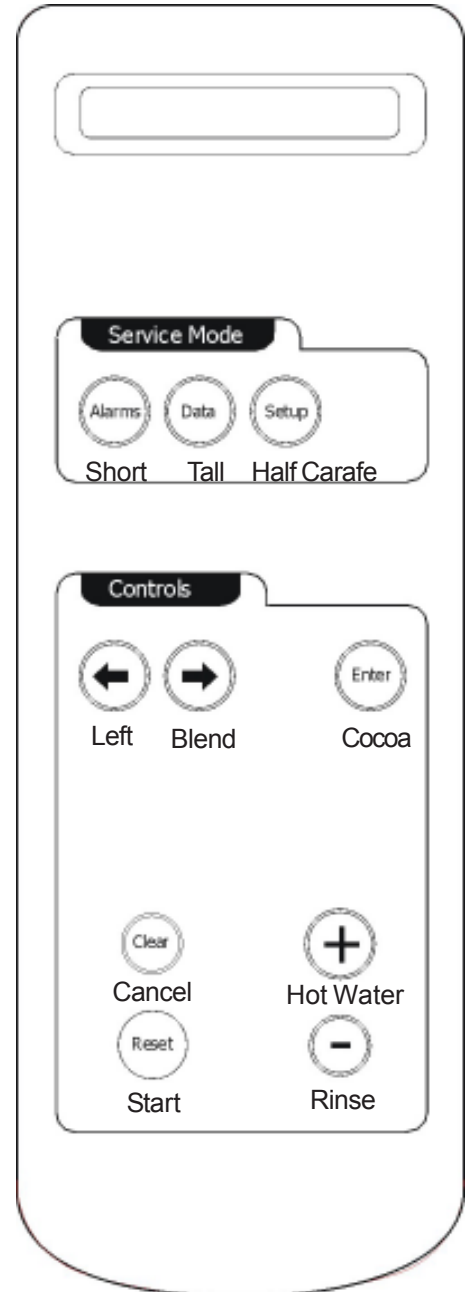
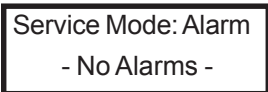

After 30 seconds of inactivity in the Service mode, the display will return to the "Choose a size" prompt.



7.2 Data

Data will keep track of the beverages dispensed and the alarms triggered. These are cumulative tally counters that can not be reset. Use the arrow keys to scroll through each message. (Read across and down)

Service Mode: Data Total bev: 00000	Service Mode: Data Short L Coffee: 00000	Service Mode: Data Tall L Coffee: 00000	Service Mode: Data 1/2 Crf L Coff: 00000
Service Mode: Data Caraf L Coffee: 00000	Service Mode: Data Short R Coffee: 00000	Service Mode: Data Tall R Coffee: 00000	Service Mode: Data 1/2 Crf R Coff: 00000
Service Mode: Data Caraf R Coffee: 00000	Service Mode: Data Short Cocoa: 00000	Service Mode: Data Tall Cocoa: 00000	Service Mode: Data Short Blend: 00000
Service Mode: Data Tall Blend: 00000	Service Mode: Data 1/2 Crf Blend: 00000	Service Mode: Data Carafe Blend: 00000	Service Mode: Data Filter paper: 00000
Service Mode: Data Low water: 00000	Service Mode: Data Low L Coffee: 00000	Service Mode: Data Low R Coffee: 00000	Service Mode: Data Low cocoa: 00000
Service Mode: Data Rinse: 00000	Service Mode: Data Waste bin: 00000	Service Mode: Data Overflow Tray: 00000	Service Mode: Data Warming up: 00000
Service Mode: Data Alarms svcd: 00000			

7.3 Setup

Setup gives you access to modify machine parameters to better suite your customer needs. Use the arrow keys to scroll through the messages. Listed are the default settings.

Activate buzzer y/n? Yes	Default selection? No	Set default size Short	Set default beverage Right Coffee
Empty waste bin 00200	Service Water Filter 25000	Right Hopper Sensor Yes	Left Hopper Sensor Yes
Cocoa Sensor Yes	Enable short cup Yes	Enable tall cup Yes	Enable carafe Yes
Enable Hot Water Yes			



SERVICE MANUAL Starbucks Interactive Cup™ Brewer

7.4 Data tracking sheet

Use this tracking sheet to record the data of the unit.

User Data

Total beverages: _____

Beverage Type	Short	Tall	1/2 carafe	Carafe
Right Coffee				
Left Coffee				
Blend Coffee				
Cocoa				

Alarm Data	Total
Filter paper:	
Low water	
Low right coffee	
Low left coffee	
Low cocoa	
Rinse	
Waste bin	
Drip tray full	
Warming up	
Alarms serviced	

Location: _____

S/N#: _____

Customer signature: _____

Date: _____

Authorized technician: _____



This page is intentionally left blank.



8 CLEANING AND SANITIZING

8.1 Cleaning and sanitizing Instructions

It is important to clean and sanitize this equipment on a regular basis in order to maintain the highest beverage quality and ensure the safety of the users. It is therefore important for anyone servicing this unit to follow Federal and State Health Department regulations. These regulations require that all parts in contact with food be cleaned and sanitized regularly and that hands be cleaned before handling these parts or other commodities such as cups and stirrers.

Cleaning and sanitizing should be done in separate steps as prescribed by health regulations and good industry practice.

Cleaning: Cleaning means "Making free of visible soil, stains or impurities". This also means removing food soils, oil or mineral deposits that could alter the beverage taste or appearance, and therefore its quality.

Sanitizing: Sanitizing means application of measures designed to protect public health. This is done by reducing bacteria remaining on the surface after it has been cleaned.

There are two sanitation methods:

- 1) Chemically, the part can be treated with a bactericidal compound to remove bacteria;
- 2) With hot water of at least 170 F, the bacteria can be killed if the temperature of the part is raised high enough.

Always unplug the unit before using water on electrical parts of the machine.

For the sanitation process to work effectively, the part must be cleaned and free of all visible food soil, completely rinsed and preferably air dried. Wiping with towels or cloths can recontaminate sanitized food-contact surfaces. Therefore, we recommend to air dry sanitized food - contact surfaces and not wipe dry.

FREQUENCY:

There are two important variables that need to be considered when evaluating cleaning and sanitizing frequencies:

- Product consumption
- Water quality

Since the expected customer usage may vary for one location to another, the cleaning and maintenance is recommended upon the given time lines or cycle counts, whichever comes first. Note that these are intended as a guideline to ensure a part does not go without cleaning. We recommend you verify each part listed in this section upon each visit and that they be cleaned as needed.

8.2 Recommended Cleaning Tools

In order to perform the following cleaning procedure effectively, we recommend that you have at least the following tools:

- Sanitation pail or bucket
- Small tube and nozzle brush, suitable for food-contact surfaces and hot water
- Medium size long and flexible brush, suitable for food-contact surfaces (coffee chute)
- Medium brush for coffee grounds, suitable for food-contact surfaces
- Disposable towels, wet-strength and lint-free
- Mild nonabrasive detergent for exterior cleaning
- Urn cleaner packets for coffee parts
- Spare parts if extensive cleaning is to be done at the shop
- Garbage bags for the waste bin



8.3 Cleaning and Sanitizing Schedule

The cleaning schedule and instructions outlined in this manual must be followed to honor the warranty and ensure consistent product quality and maintain health safety levels.



All parts should be visually inspected upon each visit and cleaned as needed.

Exterior	Daily	Weekly	Monthly	Quarterly	As needed
Waste bin	Inspect				Clean
Hopper		Inspect			Clean
Drip tray	Clean				
Unit + Stand	Clean				

Interior / Food Contact Parts	Daily	Weekly	Monthly	Quarterly	As needed
Rinsing (automatic)					Sanitize
Brewer assembly		Sanitize	Clean	Treatment	
Brew chamber		Sanitize			Clean
Cocoa whipper		Sanitize			Clean
Hopper			Sanitize		Clean
Coffee hopper funnel		Clean			
Coffee chute			Clean		
Fan			Inspect	Clean	
Cocoa canister			Sanitize		

These recommendations are based on 1,500 cycles per month, medium blend coffee and water quality levels that meet Starbucks' standards. The above recommendations will need to be adjusted if the beverage volume, coffee blends used and water quality differ.



8.4 Overall Cleaning

It is important to keep the brewer and its surroundings clean and tidy. Inspect your brewer both inside and out upon each visit and clean where needed. Please make sure that the unit is clean, safe and functioning before you leave.

8.5 Exterior Cleaning

Frequency: Daily

To minimize scratching and preserve appearance, we recommend using a clean damp sponge or soft cloth lightly treated with a nonabrasive detergent for cleaning the exterior of the unit and the base cabinet. After removing all food soils, thoroughly dry with a clean, soft cloth.



Non food-contact Parts to be verified and wiped clean

- | | |
|--|--|
| <input checked="" type="checkbox"/> Top cap | <input checked="" type="checkbox"/> Backsplash |
| <input checked="" type="checkbox"/> Metal Cabinet | <input checked="" type="checkbox"/> Cup stand |
| <input checked="" type="checkbox"/> Plastic Door | <input checked="" type="checkbox"/> Stand |
| <input checked="" type="checkbox"/> Coffee hopper exterior | |



Exterior parts requiring additional cleaning instructions (see below)

- Drip tray
- Side skirts
- Waste bin



Parts for this brewer are **NOT** dishwasher safe!

8.5.1 Cleaning the drip tray

Frequency: Daily or as needed

The drip tray is not hooked up to a drain therefore it should be inspected and emptied periodically.

WARNING, drip tray may be full.

Use caution and keep it level to avoid spilling. Remove the drip tray by simply lifting gently and pulling it out from underneath the door. Rinse both parts under water and dry thoroughly with a clean dry cloth or towel. Reinstall the drip tray onto the brewer and make sure that both prongs are secure and that the side skirts are well aligned.

If the drip tray is full, verify that the overflow is not also full. If it is, wash and dry with a cloth.

8.5.2 Cleaning the side skirts

Frequency: Daily or as needed

The side skirts can simply be wiped down. If they are submerged in water, make sure that you drain all the water out and allow sufficient time to air dry before reinstalling them on the unit.



8.5.3 Cleaning the sensors

Frequency: Weekly or as needed

The optical level sensor lenses need to be cleaned on a regular basis to ensure an accurate reading of the product levels. Their view inside the canister must also be clear. If you are experiencing difficulties, please refer to the servicing section on page 64.

8.5.4 Emptying the waste bin

Frequency: Daily or every 200 cycles*

After each coffee cycle, the spent grounds and used filter paper are automatically discarded into the waste bin located in the stand. To prevent the bin from overflowing, the unit will indicate its need to be emptied every 200 cycles, and the LCD screen will toggle between the 2 following messages:

Empty Waste Bin
Empty bin in cabinet

Empty Waste Bin
Press Cancel, Start

The equipment will not dispense beverages until the bin is emptied and the counter is reset. *This factory set counter can be adjusted to the waste bin size you use. A setting of 0 will disable this function and will cause an overflow problem if the bin is full. See the machine parameter on page 39 for more instructions on changing the setting.

How to empty the waste bin:

1. Open the cabinet door located directly below the brewer.
2. Cut the filter paper with scissors or tear gently. **DO NOT YANK ON THE PAPER!**
3. Remove the filled plastic bag from the spent grounds bin and replace with a new one.
4. Press the **Cancel** button then the **Start** button to reset the counter.



It is very important not to yank on the filter paper. Doing so may prevent the brewer from functioning properly.



To avoid this situation, have the waste bin emptied daily and reset the counter after doing so by holding the Rinse button for 3-5 seconds until the display indicates "Waste bin counter reset".



8.6 Interior Parts Cleaning & Sanitizing

For sanitary reasons, do not use soap or detergent inside the brewer. Use hot water for on-site sanitation or suitable chemical products in the shop. Wiping with towels or cloths can recontaminate sanitized food-contact surfaces. Therefore, we recommend to air dry sanitized food-contact surfaces and not wipe dry. Allow sufficient time for the parts to dry thoroughly before closing the door.



Use a medium size brush dedicated for coffee grounds and a small dust pan to easily brush away coffee grounds and dust inside the brewer before cleaning with water.



Interior Parts to be cleaned

- Cocoa Canister
- Coffee Brewer
- Coffee Funnel
- Coffee Chute
- Coffee Hopper
- Fan

8.6.1 Automatic Rinse Cycle

Frequency: Automatic (100 cycles)

Every 100 cycles, the equipment will automatically instruct the user to Rinse the machine. This process will sanitize automatically the brewer and the cocoa whipping chamber with hot water. Follow the instructions on the display carefully:



Caution! The rinse water is HOT. Be careful not to get any on you while proceeding with the following steps. Place a Tall cup (min. 12 oz.) or other suitable container below the dispensing nozzle to catch the HOT rinse water.

The display will indicate:

* Choose a size *
Please press Rinse

After pressing Rinse, the display will indicate:

Place Tall Cup and
Press Start to rinse



Caution! The rinse water is HOT. Be careful not to get any on you while proceeding with the following steps.

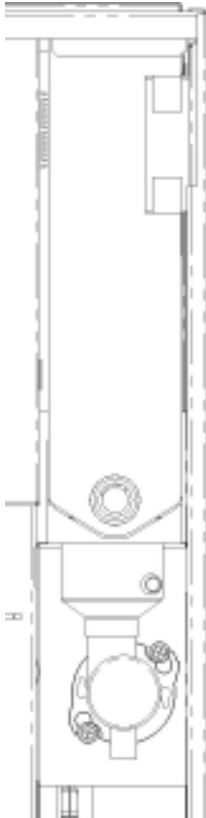

8.6.2 Cocoa Canister

Sanitizing the cocoa whipping assembly

Frequency: Weekly or every 375 cycles

This will prevent cocoa residue from attaching to the sides of the funnel.

Caution! The rinse water is HOT

1. Place a Tall cup or other suitable container below the dispensing nozzle to catch the HOT rinse water;
2. Toggle the ingredient switch to Off (SW5);
3. Order several cocoas for the hot water to flow through the system;
4. Toggle the ingredient switch back to ON;
5. Order a Tall cocoa to confirm that all parts or switches have been replaced.

Removing whipping assembly for cleaning

Frequency: Weekly or every 375 cycles

If there is cocoa residue, remove the assembly for manual cleaning under hot water:

1. Remove the tube from the base;
2. Lift off the funnel and twist off the whipper base;
3. Rinse thoroughly under hot water and use tube brush if necessary for tubing area;
4. Air dry completely;
5. Reinstall all parts in the reverse order.
6. Order a Tall cocoa to confirm that all parts or switches have been replaced.

Removing cocoa canister for cleaning

Frequency: Monthly or every 1,500 cycles

To ensure a consistent product quality, we recommend removing and emptying the cocoa canister on a monthly basis. This will ensure that the cocoa does not adhere to the walls of the canister.

1. Unlock the cocoa door;
2. Remove the cocoa sensor from the track (see page 29 for illustration);
3. Remove the top cap of the machine;
4. Pull the canister through the top of the brewer to disengage it from the motor and transmission;
5. Clean and sanitize under hot water and air dry completely;
6. Reinstall all parts in the reverse order.
7. Order a Tall cocoa to confirm that all parts or switches have been replaced.



8.6.3 Coffee Brewer

Sanitizing the Brew Chamber:

Frequency: Weekly or every 375 cycles

1. Place a tall cup or other suitable container below the dispensing nozzle to catch the HOT rinse water;
2. Toggle the ingredient switch to Off (SW5 see main board);
3. Order several coffees for the hot water to flow through the system;
4. Toggle the ingredient switch back ON;
5. Remove the brown hose and remove the brew chamber's funnel to dislodge coffee residue trapped underneath it and rinse it out;
6. Replace it and align the opening with the brown water hose so that it is against the wall to form a circular water motion around the funnel;
7. Order a Tall coffee to confirm that all parts have been replaced correctly.

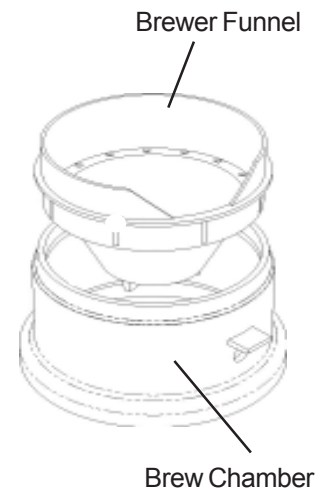

Brewer Funnel

Frequency: As needed or weekly

If there are coffee grounds accumulated, remove the assembly for manual cleaning under hot water:

1. Remove the brown water hose;
2. Lift off the funnel and pull out of the brew chamber;
3. Rinse thoroughly under hot water;
4. Air dry completely;
5. Reinstall all parts in the reverse order.
6. Order a Tall coffee to confirm that all parts have been replaced correctly.

Brewer Assembly Cleaning

Frequency: Monthly or every 1,500 cycles

In order to maintain optimal performance of the brewer assembly, we recommend that it be removed from the unit and cleaned / rinsed with hot water. (see page 61 for instructions on removing the brewer)

1. Rinse thoroughly under hot water to remove visible soil;
2. Lift off the funnel and pull out of the brew chamber;
3. Rinse thoroughly under hot water;
4. Air dry completely;
5. Reinstall all parts in the reverse order.
6. Order a Tall coffee to confirm that all parts have been replaced correctly.



**DO NOT IMMERSE THE BREWER ASSEMBLY
IN HOT WATER FOR MORE THAN A COUPLE
OF MINUTES**

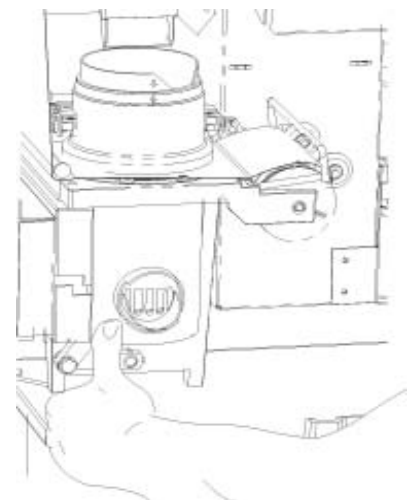



Brewer Assembly Sanitizing Treatment

Frequency: Quarterly or Every 5,000 Cycles

Regular sanitation treatments of the brewer assembly prevents residue from affecting the vacuum in the brewer mechanism and altering taste in the beverage delivered.

1. Place a Tall cup or other suitable container below the dispensing nozzle to catch the HOT sanitizing treatment;
2. Pour 1 portion of commercial urn cleaner (brand such as Urnex as directed by manufacturer) into the brew chamber;
3. Toggle the ingredient switch to Off (SW6 on the main board);
4. Select a small regular coffee on the membrane keypad and hit start;
5. Once the brew chamber is filled with water, turn the brewer OFF via the main switch at the back and wait for 5 minutes;
6. After 5 minutes, turn the brewer back ON to complete the brew cycle;
7. To rinse, make at least 2 full carafes of coffee with the ingredients set to "OFF";
8. Toggle the ingredients switch (SW6) back ON;
9. Make 2 more coffee selections to complete the rinsing cycle of the brewer.

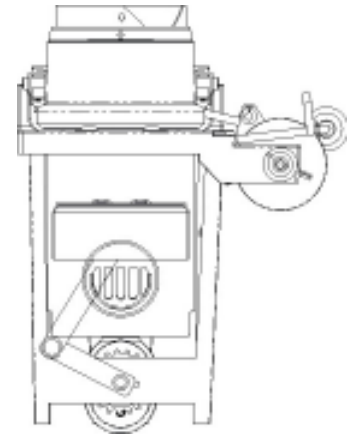

8.6.4 Coffee Hopper

Frequency: Monthly or every 1,500 cycles

The frequency for cleaning the coffee hopper parts is contingent upon the level of oil in the coffee beans used. The more oils they have, the more residue will be left. These oils, if not removed, can alter the taste and quality of the product. To reduce your time on site, we recommend swapping the hopper with a clean one and performing cleaning in the shop.

Removing the Hopper

1. Open the door of the unit;
2. Remove the top cap;
3. Unlatch the hopper from the safety pin located in the front;
4. Gently pull it towards you and up to disengage from the transmissions.

Sanitizing

1. Remove the coffee identifier cards and empty;
2. Sanitize with hot water;
3. Use urn cleaner powder for coffee oil stains;
4. Rinse thoroughly with hot water;
5. Air dry, do not wipe dry ;
6. Reinstall in the reverse order and load products.



Hopper Funnel

Frequency: Weekly or every 375 cycles

Depending upon the level of oil in your coffee, wipe the funnel with a clean DRY absorbent disposable towel to remove all excess oils at least once a week. This will ensure a consistent beverage quality. DO NOT USE WATER as it will leak into the grinder and cause damage.

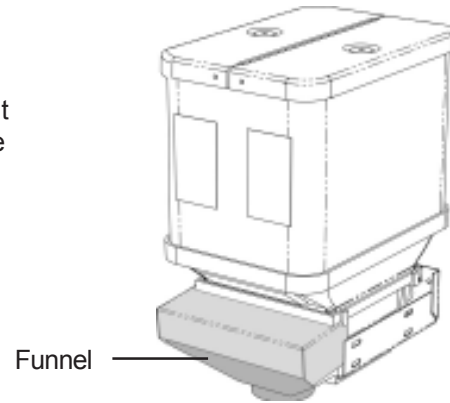

Coffee grinder chute

Frequency: Monthly or every 1,500 cycles

The chute needs to have the oil residue removed to ensure a consistent beverage quality.

1. Clean dry, with a long flexible tube brush making grounds fall into the brew chamber;
2. Eliminate these grounds from the brew chamber by ordering a coffee.

8.6.5 Fan

Frequency: Quarterly or as needed

Visually inspect the fan located directly to the right of the cocoa canister. If it requires cleaning:

1. Turn off the unit and unplug it to stop the fan;
2. Unplug the fan and remove the guard for access;
3. Wipe clean with a dry disposable towel;
4. Replace parts in the reverse order.

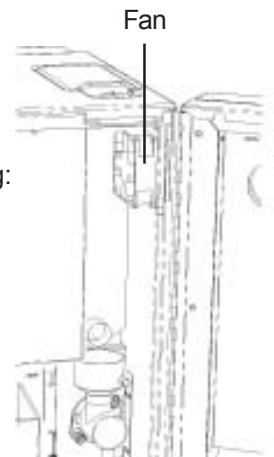



This page is intentionally left blank.



9 PREVENTIVE MAINTENANCE

All major parts of this unit need to be maintained as per the schedule to honor the warranty and to prevent them from failing. With adequate maintenance you will extend the life of your unit and deliver a consistent high quality beverage.



The preventive maintenance schedule and instructions below must be followed to honor the warranty.

9.1 Preventive Maintenance Schedule

All parts should be visually inspected upon each visit and cleaned as needed.

Parts	Monthly	Quarterly	10,000	20,000	60,000	100,000
Water Filter	Inspect			PM		
Brewer	Inspect			PM		
Outlet Valves	Inspect		PM			
Water Tank		Inspect			PM	
Grinder		Inspect				PM

These recommendations are based on 1,500 cycles per month, medium blend coffee and water quality levels that meet Starbucks' standards. The above recommendations will need to be adjusted if the beverage volume, coffee blends used and water quality differ.

We suggest that you use the service tracking sheet installed inside the door of the unit to record when parts have been serviced and maintained.



9.2 **Brewer Assembly**

PM: Yearly or every 20,000 coffee cycles

The brewer is the heart of the equipment and is responsible for the taste in the cup. It needs to be serviced regularly to maintain the quality of the beverages served. We recommend having your brewer assembly swapped with a new one that you have on hand and returned to Cafection for Preventive Maintenance every 20,000 coffee cycles registered on the counter. For a minimum charge, Cafection will completely clean and replace all parts necessary such as the cylinder, the teflon seal, and the screen and seal which are all responsible for the vacuum extraction and coffee taste in the cup. It will then be returned with a 1 year warranty against defective parts.

Contact the manufacturer for parts and additional instructions.

Inspection

The following are signs that the extraction is not being performed adequately and that your brewer may be due for preventive maintenance:

- if the seal is damaged;
- if air gets into the cylinder and creates bubbles in the coffee;
- if there are coffee grounds in the delivered product;
- if the spent coffee grounds remain wet.

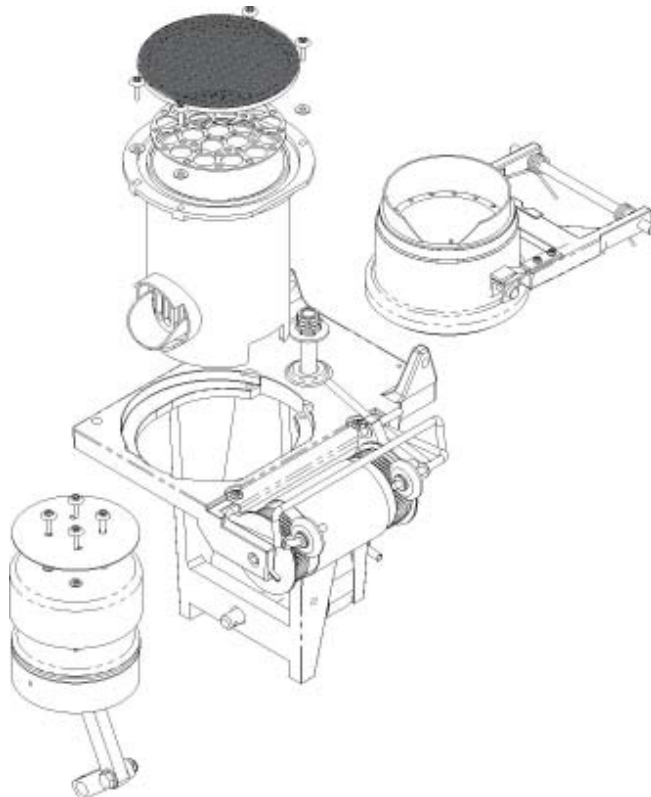



9.3 Water outlet Valves

PM: every 6 months or 10,000 cycles

To avoid any problems related to mineral deposits over time, we recommend having the 3 valves swapped, and rebuilt in your shop with the kits included in the spare parts briefcase. Refer to the manufacturer's instructions included with the valve kits.

Leaking valve

- Identify the leaking valve, change it and rebuild it
- If the leak comes from under the body of the valve or from the tank exit, try simply changing the O-ring
- If the coffee valve leaks via the tubing, water will accumulate in the brew chamber. If it drips all night, the first coffee of the morning may cause the chamber to flood since it contained too much water.

Removing and installing the valves

- Open the machine door;
- Unlock the cocoa door, unplug and remove the cocoa sensor;
- Drain the tank, see instructions page 59;
- Drain the water from the water tank into a pail until you see no water in the lowest valve;
- Unplug the 3 prongs from the valve;
- Carefully twist off the valves by pulling it towards you;
- Reinstall by repeating in the reverse order

Warning: Empty the water tank. Caution water is hot!

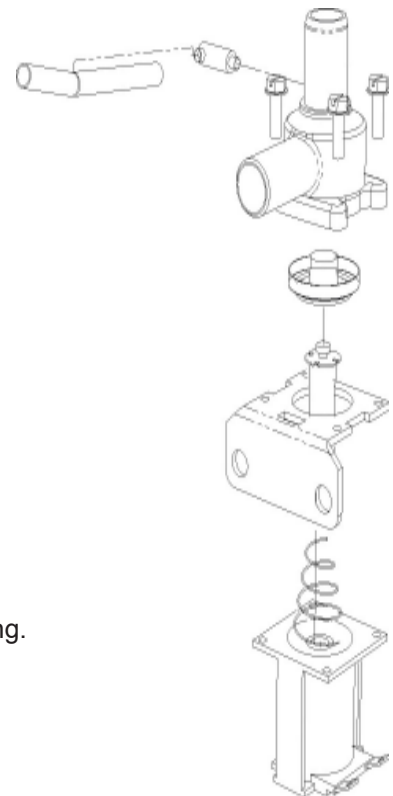
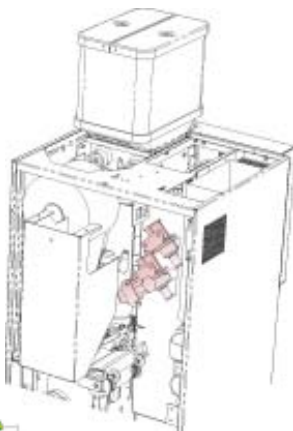

It is important to twist the valves gently so that you do not damage the O-ring.

9.4 Water Filtration System

PM: Yearly or every 20,000 cycles

Starbucks® requests that the water filter be changed every 20,000 cycles, or as required to insure that the water quality delivered in each product meets Starbucks® quality standards. When installing a new filter, please record the date and cycle count on the filter cartridge.



It is recommended that the filter be checked on a monthly basis.



9.5 Hot water tank

PM: every 60,000 Cycles, quarterly inspection

To avoid any problems related with mineral deposits over time, we recommend having the water tank assembly delimed to remove all scale in the unit. Upon visual inspection, you may wish to replace the element, thermostat and the water level and heater safety switch.

Use a scale remover product. Such as Scale Kleen by Everpure.

See the manufacturer instructions for more details.

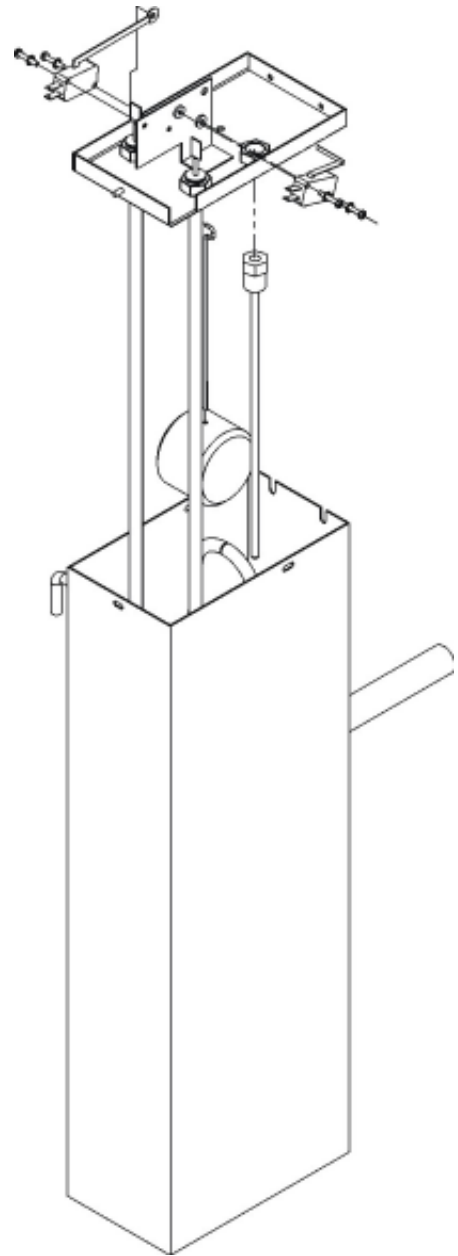



9.6 **Grinder**

PM: every 100,000 Cycles, quarterly inspection

The grinder used in the equipment is a large commercial grade burr grinder that minimizes the temperature increase in the finished product of ground coffee. The motor of the grinder has a lifetime warranty.

The ground coffee particle size is very important to achieve the desired coffee extraction. Therefore, the burrs of the grinder need to be changed once they reach about 100,000 coffee cycles.

Contact the manufacturer for parts and instructions.

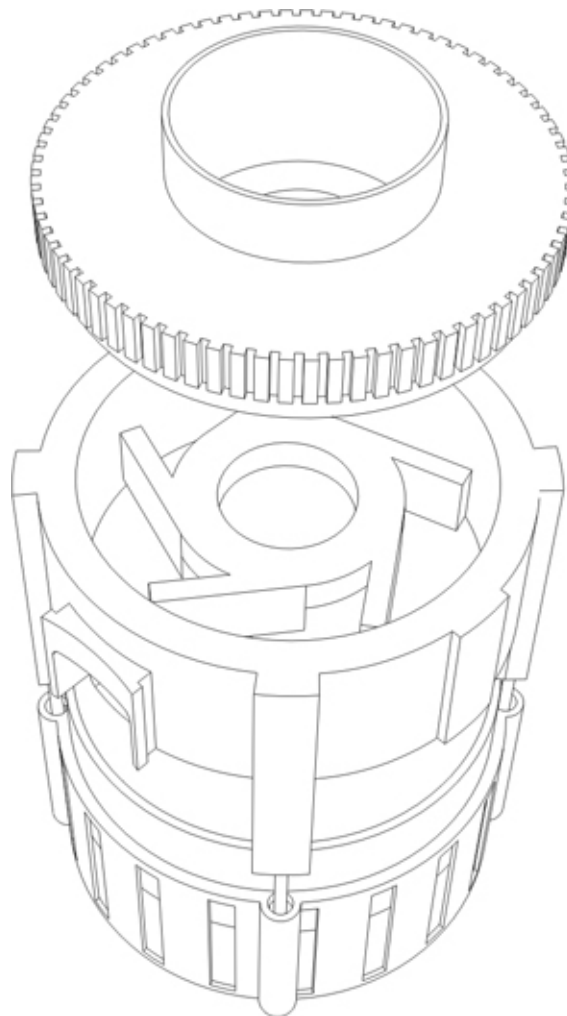



This page is intentionally left blank.



10 SERVICING PARTS

This section is intended to assist you in servicing various parts of the unit. Each page is also available in a Service Memo format that is shipped with spare parts orders.

10.1 Draining the hot water tank

We recommend allowing 3 hours for the hot water to cool prior to emptying the tank. Make sure you have a 2 gallon container suitable for holding hot water.

1. Turn off and unplug the brewer;
2. Turn off the main water supply to the machine;
3. Open the machine door;
4. Remove the machine top cap;
5. Remove the valve cap by unscrewing the top, with a screwdriver;
6. Locate the drain tube with a red plug behind the valves;
7. Direct the tube into the pail and remove the red plug. **Warning, water may be hot!;**
8. Drain the water from the water tank completely.

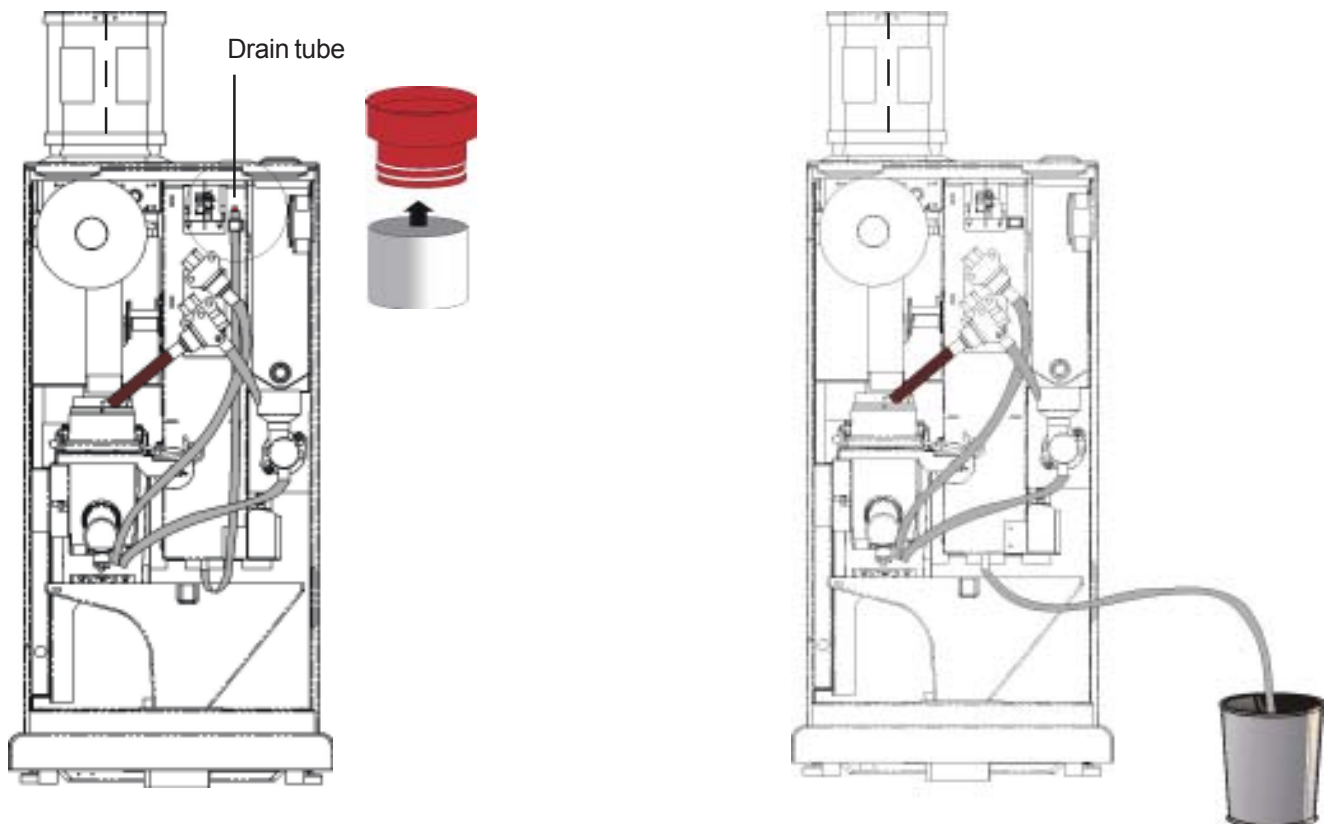



10.2 Shutdown / Storage

Should you need to store this brewing equipment for an extended period of time, follow this procedure to avoid any risk of injury or damage to the equipment.

1. Turn the unit off and unplug from the power outlet;
2. Drain the hot water tank (see instructions Page 59);
3. Empty the cocoa canister and the coffee canister;
4. Clean all parts of the unit before storing (see section 8, Page 43)
5. Disconnect the white double wire from the heating element (see installation diagram)
6. Tie down the water level switch's arm with a "tie-wrap" to keep the float from pulling down on the switch during transportation. Do not overtighten, this may damage the switch; this is simply to keep the float from bouncing up and down on the switch.

10.2.1 **Storing the Brewer**

The brewer is the heart of equipment and is responsible for the taste of the cup of coffee. It is therefore important that you store it properly when it is not in the brewer. Always disengage your brewer clutch by using a pair of pliers and turning the pin located on the back clockwise until the brew chamber lifts up. This will release the pressure on the screen and seal. Your brewer must be on its back or its left side while on a table top. Do not sit the brewer on its right side (wheels and yoke) or straight up as these positions are not sturdy and could cause it to fall.



10.3 Brewer assembly

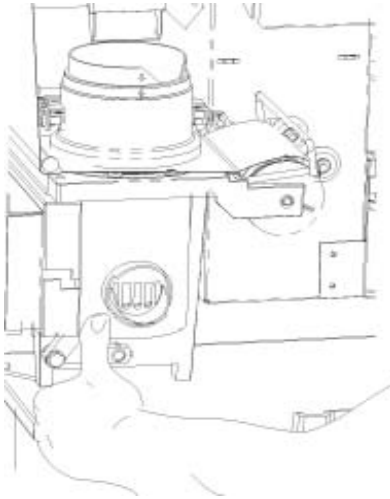

Removing the brewer

1. Open the machine door;
2. Togle the brewer switch (SW4 see page 16) to release the filter paper and cute the filter paper;
3. Remove the coffee spout and the hose support bracket from the right side of the brewer assembly;
4. Support the brewer assembly by holding the aluminum shaft on the right side of the brewer assembly;
5. With your left hand, slide the retaining pin over to the right and then down;
6. Pull the brewer assembly straight towards you.

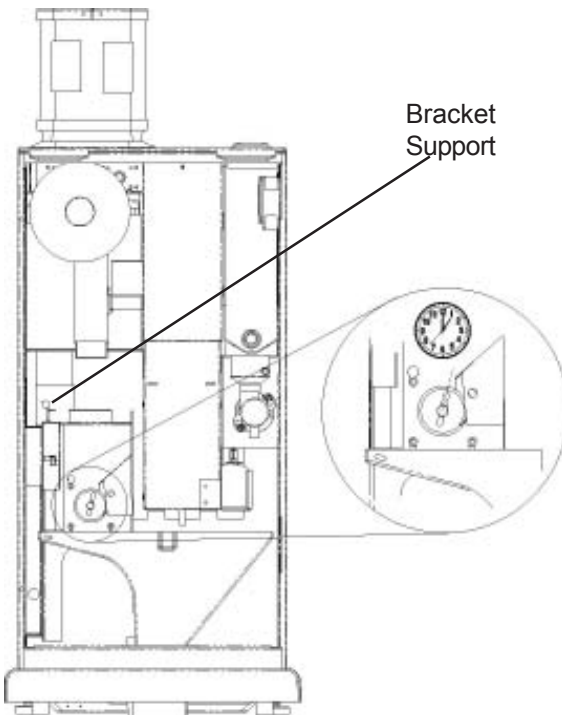

Installing the brewer

1. Make sure that the dog drive pin in the back of the brewer is at 1 o'clock;
2. Align the left edge of the brewer on the left bracket support;
3. Push the brewer back completely into the dog drive motor;
4. Slide the brewer's retaining pin up and then left.

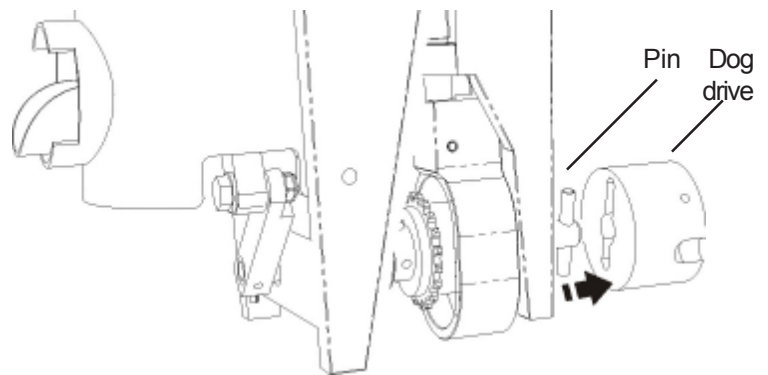



10.4 Microcontroller (EPROM)

The microcontroller, also known as the Eprom, can be swapped out to incorporate new improvements to the programming such as new settings or new functions.



- Please take all counter readings before changing the microcontroller because all data will be reset.
- Use the necessary precautions for handling static sensitive devices.
- Do not attempt to pry the chip out of the socket with anything. This will damage the casing.

Tool required: You will need to purchase a PLCC Extractor as showed in the diagram below named. This can be found in most electronics stores or via the internet. Without this tool, you may damage the casing for the microchip and damage the board.

Removing

1. Retrieve all your data;
2. Turn off the machine and unplug from the outlet;
3. Open the door and remove the lexan plate via the 4 screws;
4. Locate the microcontroller (the black square piece in the middle of the board with a white label);
5. Using the Extractor, carefully insert the prongs in the top right and bottom left corner slots of the casing and grab the microcontroller;
6. Lift out of the socket gently.

Replacing

1. Align the notched corner of the microcontroller with the notched corner of the empty socket;
2. Make sure that all contacts are aligned with the appropriate slots on the socket;
3. Push the microcontroller firmly, straight down until the top of the chip is flush with the top of the socket;
4. Replace remaining parts in the reverse order;
2. Plug the machine in and turn on the unit;
3. At start-up, the display will indicate the microchip version #;
4. Test the new features outlined in the documentation supplied with the new microcontroller.

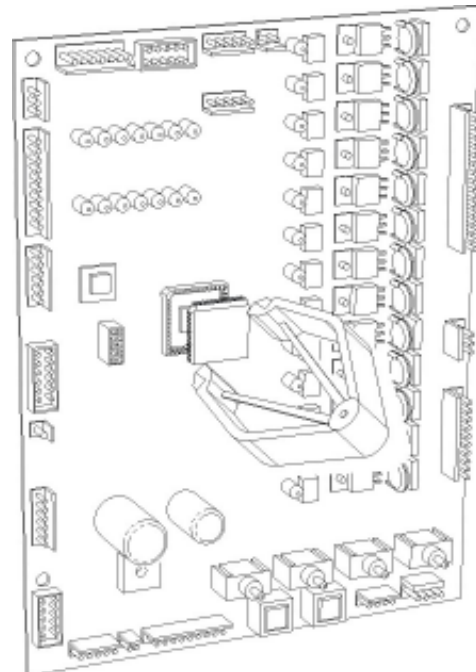
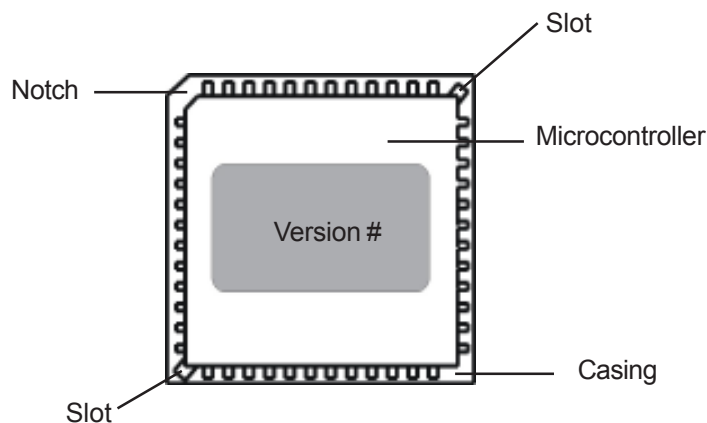



10.5 Main Board

Like all electronic main boards, they are very susceptible to power surges in the building. If this is your reason for changing the main board and this persists, verify your power source. Use the necessary precautions for handling static sensitive devices.

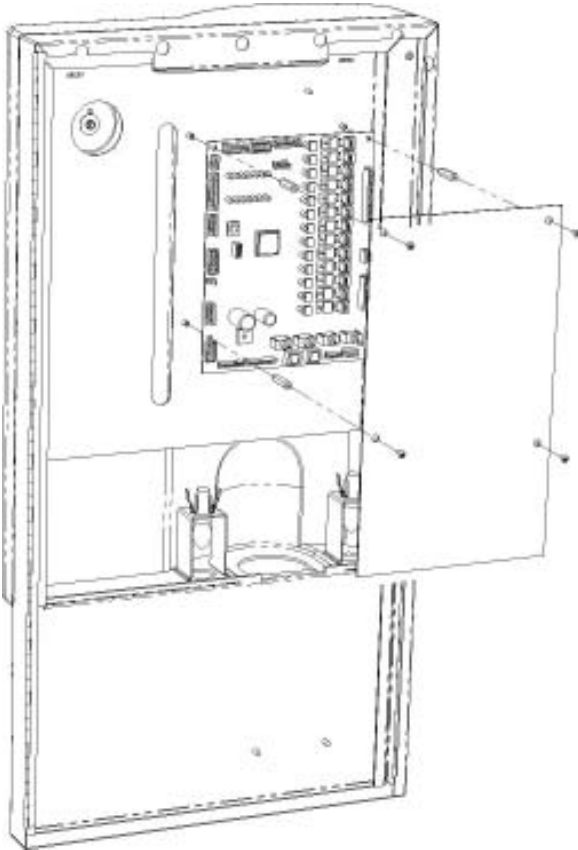

Removing

1. Retrieve all your data;
2. Turn off the machine and unplug from the outlet;
3. Open the door and remove the lexan plate via the 4 screws;
4. Unplug the connections: (Clockwise from the top left corner)
 - J11, Exp #1. Exp #2
 - J18, J12, J19
 - J3, J6
 - J16, J24, J10
5. Unscrew 4 plastic 1" posts;
6. Remove the board.

Replacing

1. Replace the board and fasten with the 4 posts;
2. Plug the connections and refer to the board diagram for full size view on page 16;
3. Verify that all is in place, the board will fail if the connections are reversed or in the wrong place;
4. Replace all parts in the reverse order;
5. Plug in the brewer and turn it on;
6. Verify on the LCD that all is functioning.



All cables must be replaced in the correct order and direction before turning the power on or the board will fail and be damaged.



10.6 Keypad Membrane

The instructions below also apply for changing the following components:

- **The Membrane**
- **The display**
- **The LEDs on the keypad board**

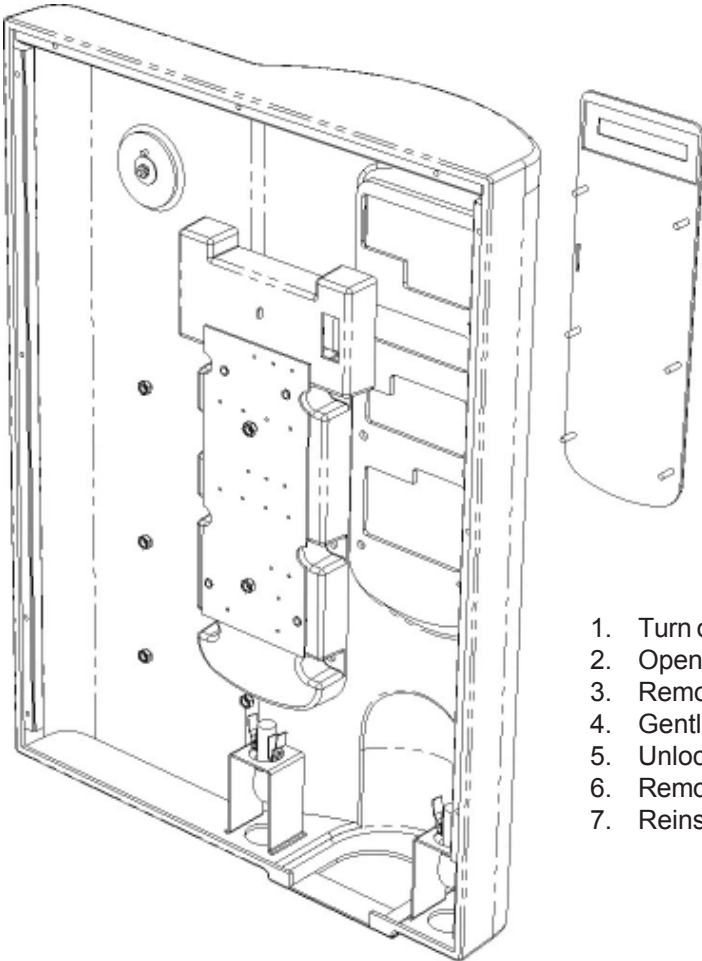

1. Turn off and unplug the brewer;
2. Open the machine door;
3. Remove the screws around the frame retaining the plastic front;
4. Gently unplug the 3 cables from the PCB board;
5. Unlock the 6 retaining nuts on the keypad chassis;
6. Remove the membrane;
7. Reinstall all parts in the reverse order.



10.7 Logo Badge

Unscrew from the inside of the door. When replacing, please make sure that it is on straight.

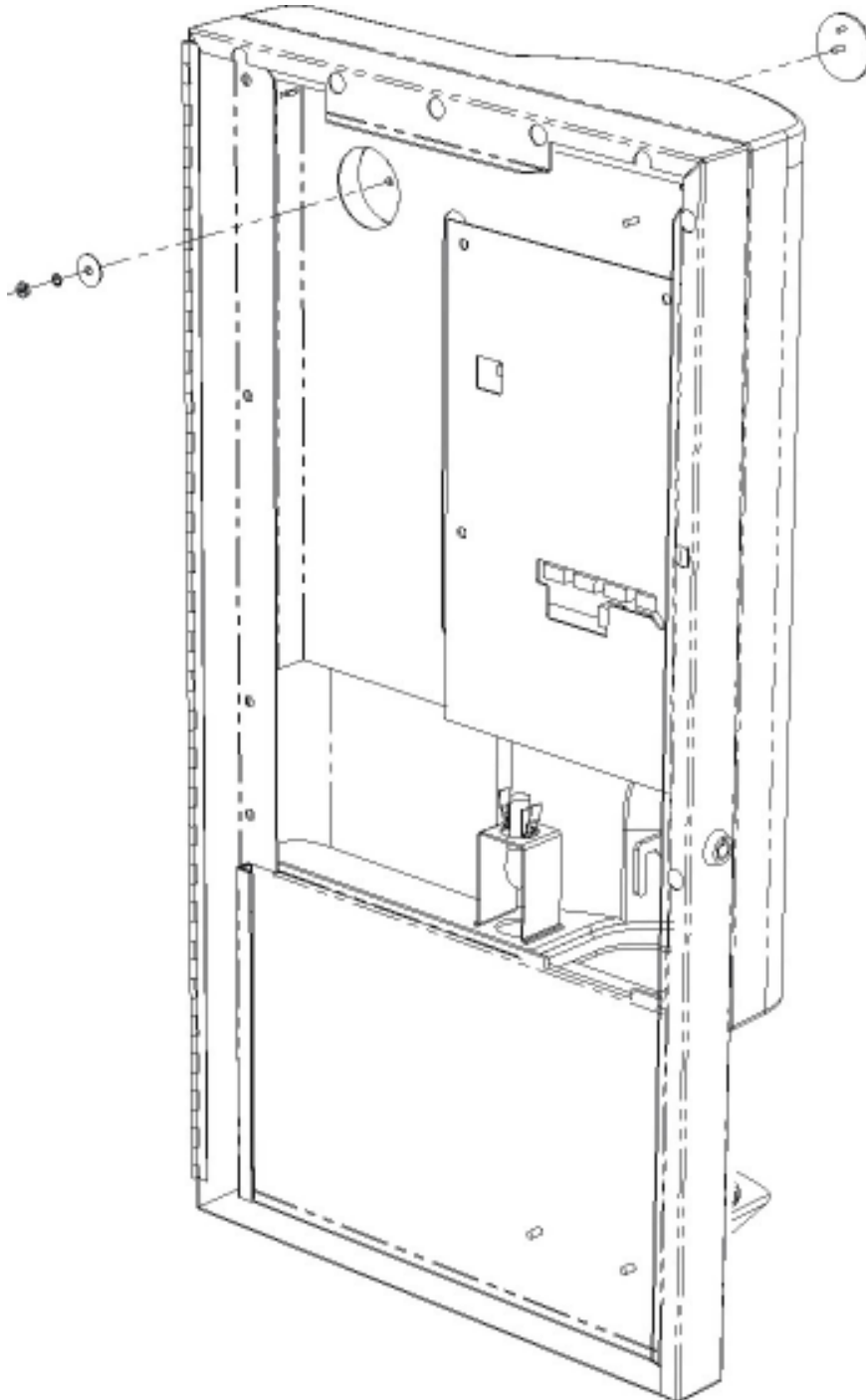



10.8 Ingredient Motor

Although they may appear the same, the coffee and cocoa ingredient motors are very different . They can be differentiated by the color of the transmission (gear shift).

The coffee ingredient motor transmission is black and has brakes. The cocoa ingredient motor is white and has no brakes. **These cannot be reversed.**

1. Turn off and unplug the brewer;
2. Open the machine door;
3. Unlock the cocoa door, remove the cocoa sensor from the track;
4. Remove the machine top cap;
5. Unscrew the back panel of the unit;
6. Unplug the motor to be changed;
7. Unscrew the motor;
8. Replace all parts in the reverse order.

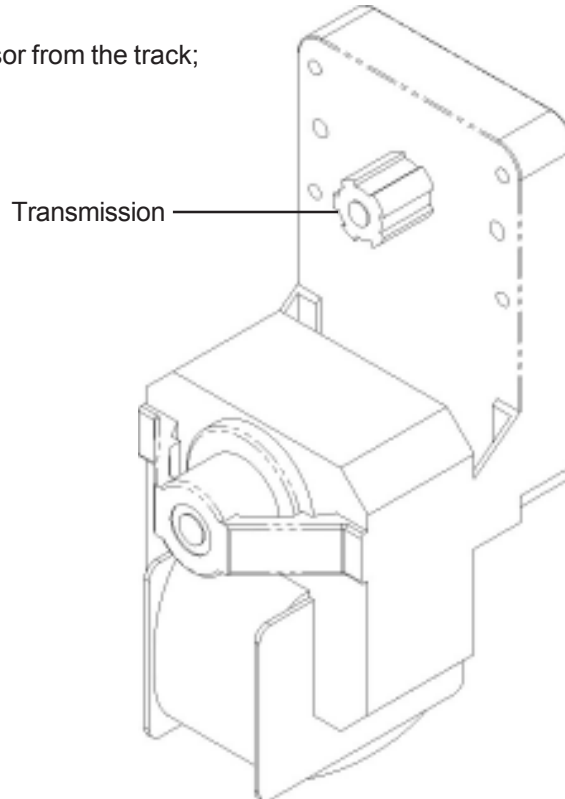



SERVICE MANUAL Starbucks Interactive Cup™ Brewer

11 TROUBLESHOOTING

This troubleshooting guide is provided to identify probable causes and remedies for the most likely situations encountered. The following procedures must be performed by a qualified service technician. If the problem persists after exhausting the troubleshooting steps, contact the manufacturer at 1-800-561-6162. Please have the model and serial number available.

11.1 LCD Messaging

The LCD screen will display 2 types of alarms: those that can be cleared by the user and those that require the attention of a certified service technician. Either type of alarm may prevent use of the brewer until the alarm is cleared.

Type 1 - Alarms to be cleared by the User:

Message	Cause	Remedy
* Choose a size * Add regular coffee	Regular coffee sensor is activated and sensing low coffee	Add regular coffee, see page 33
* Choose a size * Add decaf coffee	Decaf coffee sensor is activated and sensing low decaf coffee	Add decaf coffee, see page 33
* Choose a size * Add cocoa	Cocoa sensor is activated and sensing low cocoa	Add cocoa, see page 33
Share your thoughts with Starbucks Call 888-494-5282 or ocs@starbucks.com	Automatic tally counter triggered	Call or email to share your thoughts on the equipment and/or the products To clear the message, order a beverage
* Choose a size * Please press Rinse Place Tall Cup an Press Start to Rinse	Automatic tally counter triggered	Follow the instructions to rinse both the coffee and cocoa dispensing mechanisms
Empty Waste Bin Empty bin in cabinet Empty Waste Bin Press Cancel, Start	Automatic tally counter has reached 200, Waste bin is full	Follow the instructions to empty the bin and reset the counter, see page 46
Option Unavailable	The selected feature has been deactivated via the software	a) See page 40 for product features via the setup menu

Type 2 - Alarms requiring technical assistance

Message	Cause	Remedy
* Service required * Low water level	Water level in the hot water tank is too low	a) Verify your main water source is open b) Verify the water level switch is clean and well adjusted c) Verify the overflow tray is dry
* Service required * Drip tray full	There is water in the overflow drip tray located below the drip tray	a) Clean and dry the overflow tray b) Confirm where the water came from
* Service required * Brewer error	Brewer cam position is not being located	a) Verify that the brewer and the dog drive pin are not soiled b) Verify the pin is in place and well installed See P. 61



Type 2 - Alarms requiring technical assistance (Continued)

Message	Cause	Remedy
* Service required * Warming up	Water in the hot water tank is not at brewing temperature	a) Verify the water temperature, P. 31 b) Verify heater switch is adjusted, P. 27
* Service required * Filter paper required	The filter paper is low or missing	a) Replace the roll of paper by following the instructions P. 35

11.2 Parts specific

Symptom	Cause	Remedy
Flood in brew chamber Coffee backup	Bad extraction will cause the chamber to flood wet coffee grounds	a) Verify you are using Starbucks filter paper b) Verify that the filter paper is properly installed see P.35 c) Verify the product in hopper is Starbucks whole bean coffee and not cocoa or ground coffee d) Verify your brewer parts see P. 54 e) If it's the first coffee of the morning, the coffee valve is leaking see P. 55
Water is warm	Element is not heating	a) Verify the connectors are properly installed and your switches are clean and adjusted P. 27 b) Verify water temperature P. 31 c) Verify the condition of the element
Warming-up message appears often	Heater safety switch is not well adjusted	a) Verify the switch adjustment P. 27 b) Verify your thermostat set-point P. 31
Machine seems off or not responding	One of the safety cutoff measures has been triggered P. 21	a) Verify that the overflow cup is empty P. 28 b) Verify the water level switch adjustment P. 27
Quantity of liquid in the cup is too low	The valves are clogged up or the the switches need adjustment	a) Verify the water level switch adjustment P. 27 b) Verify that the outlet valves are not affected by lime P. 55
Water valve is leaking	The valve's seal is affected	a) Identify the valve in trouble and change it P. 55
No light when brewing	The lights are burned out	a) Change the light bulbs located inside the door
The machine is brewing coffee on its own	The carafe option has been selected	a) The carafe option can be deactivated via the software see P. 40
The coffee is weak	Various	a) Verify that Starbucks coffee is being used and that the hopper is full b) Verify the water temperature P. 31
Grounds in coffee	The filter paper failed	a) Verify that you are using Starbucks filter paper and that is properly installed P. 35
Unpleasant taste	Water tank or brewer needs cleaning	a) Verify that the cleaning schedules are followed



Parts Order Form

Tel: 1-800-561-6162
Fax: 1-800-463-2739

order@cafection.com

P/O # :

Customer # :

Machine model

C

Bill to: _____

Phone : _____
Fax : _____
e-mail : _____

Ship to: _____

Phone : _____
Fax : _____

Shipping:	
Regular :	
*Overnight :	

Qty :	Part # :	Complete Description	Model :	Price

* Order must be received by 12:00 EST for Overnight Shipping

	Fax bid to confirm Prices & Order
--	-----------------------------------

Signature : _____
 Print Name: _____

Date: _____



Parts Return Form

2355 Dalton, Quebec(Qc) G1P 3S3 Canada

Tel: 1-800-561-6162
Fax: 1-800-463-2739

RMA # :

Customer # :

Company : _____
Contact : _____

Tel: _____
Fax: _____
E-Mail: _____

Shipping _____
Prepaid #: _____

To process your return promptly without any delay, the **Parts Return Form** must be:
Fully completed, faxed to Cafection for authorization & enclosed with your return.

Qty:	Part Number:	Serial Number:	Specific Problem : (Must be completed)

Repair	Exchange	*Credit

* Invoice Reference number is necessary for credit : # _____

Signature: _____ Date: _____

Last update, March 2010 C.A.